

JetWave 2640

Outdoor Long Range Dual Band IEEE802.11a + 802.11b/g Wireless AP



CE RoHS



- Supports both IEEE 802.11a 5.8GHz and 802.11b/g 2.4GHz band
- Up to 54Mbps maximum net data rate
- High Gain 23dBi Panel Antenna maximizes transmission distance up to 40KM
- N type external Antenna slot
- Wireless QoS (WMM) for video precedence transmission
- Supports Base Station, CPE, Point to Point and Point to Multiple Point Connectivity
- Intel TDMA Technology for long distance connectivity
- Multiple Data Encryption algorithms, including WEP,WPA,WPA2
- Secured Access Control by HTTPS, SSH, 802.1x, MAC
- Auto ACK-Time adjustment, Link test for easy installation
- Rugged IP67 Protection Housing for outdoor installation
- Power supply compatible with PoE Source
- -30~70°C operating temperature for hazardous environment application

Installation

JetWave 2640 supports one 802.11a and one 802.11b/g interface, one panel antenna and an external antenna interface for 802.11b/g band. The optional antenna allows users to transmit data to clients directly.

With the JetWave 2640, users do not need to purchase additional 802.11b/g AP since most CPE(clients) are already embedded with 802.11b/g NIC. The dual band design is suitable for the first or last AP of the long distance transmission.

JetWave without Dual Band

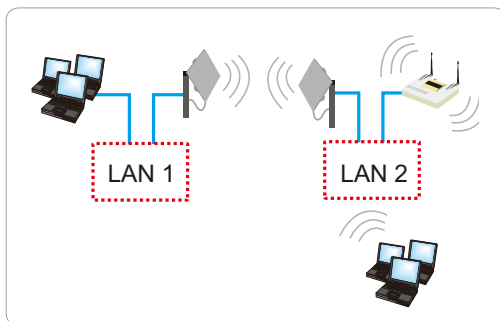

JetWave 2640 Dual Band

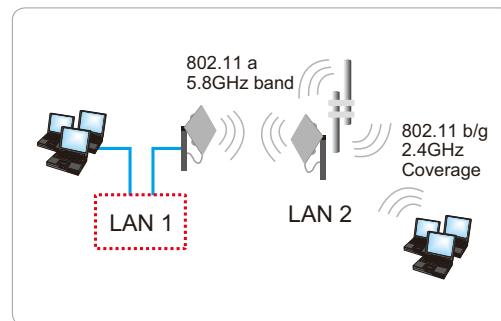

JetWave Application – Typical Outdoor AP Solution

- Base Station and CPE Communication
- P2P using Bridge or Relay Feature

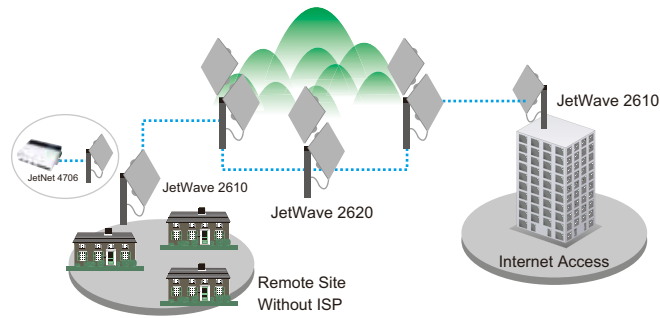

- Industrial Intelligent NMS
- Rackmount PoE Plus Switch
- Industrial PoE Plus Switch
- Industrial 12-24V PoE Switch
- Industrial PoE Switch
- Rackmount L3/L2 Switch
- Gigabit Managed Switch
- Managed Ethernet Switch
- Entry-level Switch

JetWave Application – Dual Band Outdoor AP Solution

- Support both 802.11a and 802.11b/g
- Tunnel/Road site Transportation

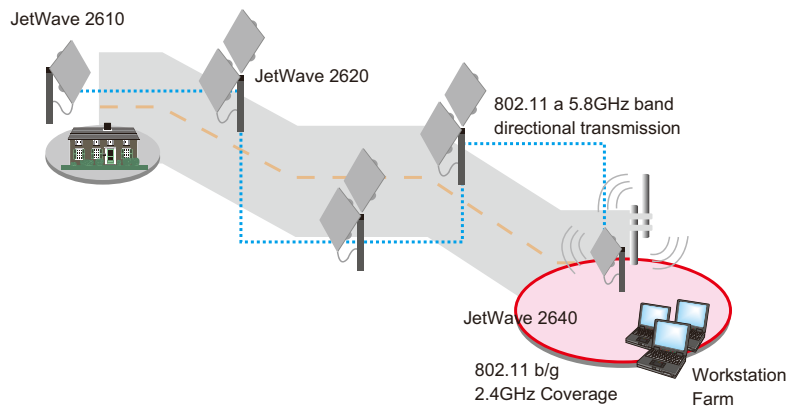

- Wireless Outdoor AP**
- Embedded PoE/Router Computer (LINUX)
- Industrial Communication Computer (WIN/LINUX)
- Ethernet/PoE/Serial Board
- Ethernet I/O Server
- Media Converter
- Serial Device Server
- SFP Module
- Din Rail Power Supply

JetWave 2600 Series Appearance

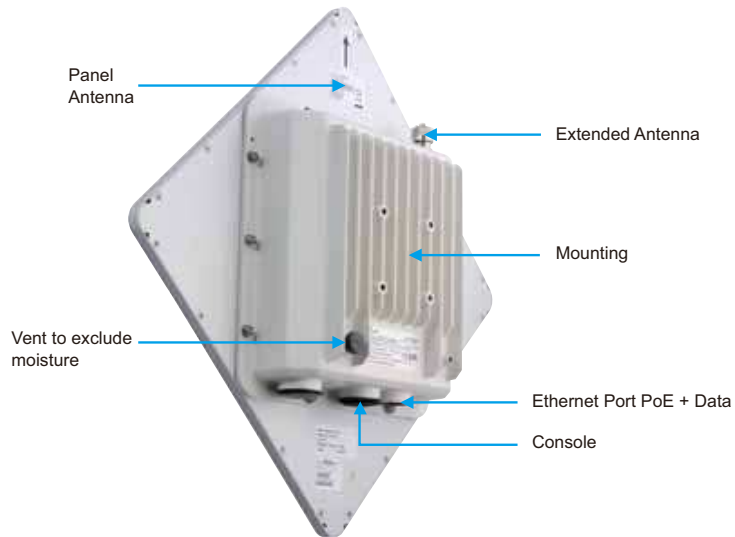

Dimensions (Unit = mm)

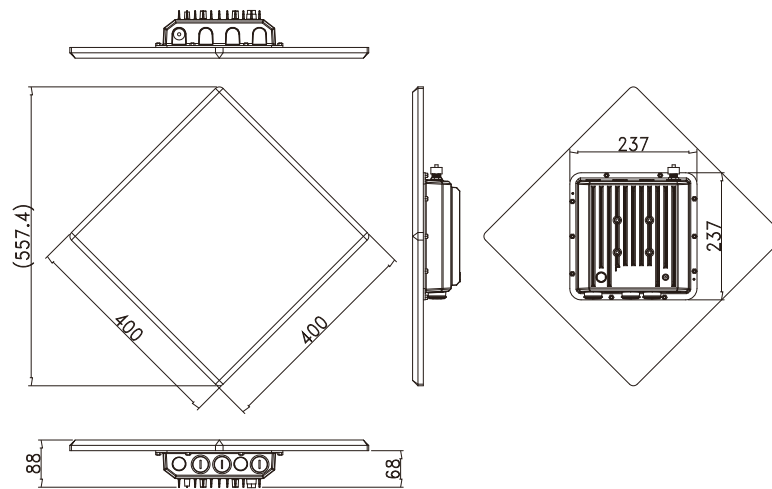

Specification

Technology

Standard:

IEEE 802.11a/b/g for Wireless LAN
 IEEE 802.11i Wireless Security
 IEEE 802.3u for 10/100Base-TX
 IEEE 802.3af for Power over Ethernet
 IEEE802.1D Spanning Tree Protocol

Performance

CPU: IXP425, 533MHz

System Memory:

16MB Flash
 32MB SDRAM

Operating Frequency:

5.8GHz Band:

FCC* : 5.725~5.850 GHz
 CE** : 5.470~5.600 GHz; 5.650~5.725 GHz

2.4GHz Band:

FCC : 2.412~2.462GHz
 CE : 2.412~2.472GHz
 (Programmable for different country regulations)

RF Modulation:

802.11a: OFDM (BPSK, QPSK, 16-QAM, 64QAM)
 802.11b/g: DSS (CCK, DQPSK, DBPSK)

RF Output Power (Max. of Avg.):

5.8GHz Band:

24dBm at Radio for FCC (Band 4)
 30dB EIRP for ETSI 301 893 (Band3)

2.4GHz Band:

23dBm (Max. of Avg.) at Radio for FCC
 20dB EIRP for CE (ETSI 300 328)
 (Controllable for different country regulations)

Sensitivity:

5.8GHz Band:

≤-90dBm @6Mbps
 ≤-73dBm @54Mbps

2.4GHz Band:

≤-96dBm @1Mbps
 ≤-90dBm @6Mbps
 ≤-72dBm @54Mbps

Default Antenna Characteristics

Gain: 23dBi

Frequency: 5400~5850 MHz

Direction: Directional Antenna

HPBW (Horizontal): 10 Deg.

HPBW (Vertical): 10 Deg.

Interface

Ethernet Port: 1 x 10/100Base-T, Auto Negotiation

RS-232: RS-232 (UART) in RJ45 Form Factor For debug purpose

P1: TXD0, P2: DSR0, P3: RXD0, P4: TXD1,
 P5: RXD1, P6: DTR1, P7: Hard Reset, P8: GND

Buzzer: Embedded buzzer for power on and Antenna Alignment indication

Reset Pin:

Short P7 and P8 less than 1 sec. to reset system
 Short P7 and P8 less than 5 sec. to reset to factory default

Cables: 2/4-pair UTP/STP Cat. 5 cable (100m)

Management

Management: Web UI (Secure SSL), Command Line Interface (SSH or RS-232 (9600)), Windows-based Utility, SNMPv2, DHCP Client, Configuration backup/restore,

Statistics: Wireless and Ethernet Traffic statistics

Firmware upgrade: Web, Windows management tool, TFTP, firmware backup

Operating Mode:

JetWave 2610/2640: Base Station, CPE, Point to Point, Point to Multiple Point

JetWave 2620: Base Station, CPE, Relay, Point to Point, Point to Multiple Point

Radio Bandwidth Control: 5MHz/10MHz/20MHz/40MHz

Super A/G: Fast Frames, Burst, Compression modes

TDM Coordination: Traffic management

Intel TDMA: For long distance transmission

Transmit Power Control: Adjust RF output power

Link Aggregation: To enhance Throughput with dual radio card (2620 only)

Distance in Meters: Auto ACK-Time adjustment

Wireless Isolation: Isolate Wireless data from clients

Antenna Alignment: Easy tool to align antenna performance

Link Test: Self-Wireless Connection test

Secured Access: HTTPS, SSH, 802.1x, Radius Server, Access Control by Trusted Wireless station, manually add station, MAC Address Authentication

Security Encryption: WEP 64/128/152 bits, WPA-PSK (TKIP), WPA2-PSK(AES), Mixed WPA/WPA2

STP: Spanning Tree Protocol with Fast Forwarding

NTP: Network Time Management

System Log: Log occurred events

Power Requirements

Power: Power over Ethernet, IEEE802.3af compliant

PoE Injector:

Input: 100-240VAC, 0.6A 50-60Hz

Output: 48V, 0.4A

Power Consumption: Above 6 Watts @ DC 48V, depend on user volume

Mechanical

Enclosure: IP-67 & Level 17 Beaufort Scale protection

Vent: Vent for exclude moisture

External Antenna connector: N-Type

Dimension:

Box: 237 mm (H) x 237 mm (W) x 68 mm (D)

Antenna: 320 mm (H) x 320 mm (W) x 18 mm (D)

Installation: Pole Mount (ADC-12 Aluminum alloy)

Weight: 4.43 kg with package

Environmental

Operating Temperature: -30 ~70°C

Operating Humidity: 10% ~ 95% (operating)

Storage Temperature: -40 ~ 85°C

Regulatory Approvals

EMI: FCC part 15 Subpart B&C, CE EN301 893(5G)

EMS: CE EN301 489-1/17

Shock: IEC60068-2-29

Vibration: IEC60068-2-6

Free Fall: IEC60068-2-32

Warranty: 3 years

Industrial
Intelligent
NMS

Rackmount
PoE Plus
Switch

Industrial
PoE Plus
Switch

Industrial
12-24V
PoE Switch

Industrial
PoE Switch

Rackmount
L3/L2 Switch

Gigabit
Managed
Switch

Managed
Ethernet
Switch

Entry-level
Switch

Wireless Outdoor AP

Embedded
PoE/Router
Computer
(LINUX)

Industrial
Communication
Computer
(WIN/LINUX)

Ethernet/PoE/
Serial Board

Ethernet
I/O Server

Media
Converter

Serial Device
Server

SFP Module

Din Rail
Power Supply



Ordering Information

JetWave 2610-EU Outdoor Long Range IEEE 802.11a Wireless AP, CE Frequency

JetWave 2620-EU Outdoor Long Range Dual IEEE 802.11a Wireless AP, CE Frequency

JetWave 2640-EU Outdoor Long Range Dual Band IEEE 802.11a + 802.11b/g Wireless AP, CE Frequency

JetWave 2610-US Outdoor Long Range IEEE 802.11a Wireless AP, FCC Frequency

JetWave 2620-US Outdoor Long Range Dual IEEE 802.11a Wireless AP, FCC Frequency

JetWave 2640-US Outdoor Long Range Dual Band IEEE 802.11a + 802.11b/g Wireless AP, FCC Frequency

Includes:

- JetWave Unit with integrated 23 dBi antenna
- Mounting Kit
- PoE Injector & Power cord
- Grounding Wire with Screw
- Waterproof RJ-45 Connector Kit
- Quick Installation Guide
- Document CD

Notice: Choose the available Radio Frequency for your country

Optional Antenna

Model Name	Description	Apply to	Apply to
JWA-5.8G-23dBi	Directional Panel Antenna 23dBi	JetWave 2620	Antenna Unit, Mounting Kit, 1m RF Cable, V-shape steel plank
JWA-5.8G-15dBi	Directional Panel Antenna 15dBi	JetWave 2620	Antenna Unit, Mounting Kit, 1m RF Cable
JWA-2.4G-15dBi	Omni-Directional Antenna 15dBi	JetWave 2640	Antenna Unit, Mounting Kit, 1m RF Cable
JWA-2.4G-12dBi	Sector-Directional Antenna 12dBi	JetWave 2640	Antenna Unit, Mounting Kit, 1m RF Cable
JWA-2.4G-9dBi	Omni-Directional Antenna 9dBi	JetWave 2640	Antenna Unit, Mounting Kit, 1m RF Cable
JWA-2.4G-5dBi	Omni-Directional Antenna 5dBi	JetWave 2640	Antenna Unit, Mounting Kit
JWA-Arrestor-5803	0-5G Arrestor for N-Type Antenna	All	

Power Source Device (PSE)

JetNet 4706 Industrial 6-Port Managed High Power PoE Switch

JetNet 4706f Industrial 6-Port Managed High Power PoE Fiber Switch

JetNet 4706f-w Industrial 6-Port Managed High Power PoE Fiber Switch w/ wide temp

JetNet 3706-RJ Industrial 6-port RJ45/IP67 PoE Switch

JetNet 3705 Industrial 5-port Power Over Ethernet Switch

JetNet 3705f Industrial 5-port Power Over Ethernet Fiber Switch

Note: Users would raise the power consumption to maximum.

To provide enough power, the High Power PoE Switch is recommended.