

**Korenix JetNet 3810G Series**  
**JetNet 3810G/ 3806G/ 3710G**  
**Industrial Power over Ethernet GbE Switch**

---

**User's Manual**

First Edition, June 2010



[www.korenix.com](http://www.korenix.com)

# **Korenix JetNet 3810G Series**

## **JetNet 3810G/ 3806G/ 3710G**

### **Industrial Power over Ethernet GbE Switch**

# **User's Manual**

#### **Copyright Notice**

Copyright © 2008 Korenix Technology Co., Ltd.  
All rights reserved.  
Reproduction in any form or by any means without permission is prohibited.

# Index

Index.....	2
1. Introduction .....	3
1.1 Overview .....	4
1.2 Product Features .....	4
2. Hardware Installation.....	5
2.1 Hardware Introduction .....	5
Dimensions.....	5
Front Panel .....	7
Bottom View .....	8
LED Indicators.....	8
2.2 Wiring the Power Inputs.....	9
2.3 Wiring the Relay Output .....	11
2.4 Wiring Earth Ground .....	11
2.5 DIP Switches .....	12
2.6 Wiring the Ethernet Ports.....	12
2.7 Connecting Powered Device (PD) .....	13
2.8 DIN-Rail Mounting Installation.....	15
3. Appendix .....	16
3.1 Product Specification .....	16
3.2 Revision History.....	18

# 1. Introduction

Korenix JetNet 3810G Series is a power over Ethernet rail switch that is specially designed for industrial or commercial applications. The following topics are covered in this chapter:

1.1 Overview

1.2 Product Features

## 1.1 Overview

JetNet 3810G series, Industrial Power over Ethernet (PoE) GbE Switches, are designed with 8/4 Fast Ethernet PoE ports and 2Gigabit uplink ports to ensure high-bandwidth uplink connection for wide PoE markets. This series include JetNet 3810G/ 3806G/ 3710G which are all compliant with IEEE 802.3af PoE standard to deliver maximum 15.4Watts per port. For JetNet 3810G/ 3806G model, it integrates with Korenix patented power boost technology- Input DC 12~24V boosting to 48V built-in power booster which is the best solution for the vehicle PoE applications with standard DC 48V power supply unavailable.

To ensure the high quality of video data transmission, JetNet 3810G series not only provide Gigabit bandwidth uplink for large image traffic, but also support QoS to adjust the priority of data transfer. With the feature of Fault Relay, JetNet 3810G series could automatically warn administrator if any abnormal situation happens. The compact size with IP-31 rigid aluminum case allows JetNet 3810G series to be reliably operated in -25~70°C extreme environment.

## 1.2 Product Features

Korenix JetNet 3810G/ 3806G/ 3710G have the following features:

	JetNet 3810G	JetNet 3806G	JetNet 3710G
<b>Features Highlight</b>			
10/100 TX PoE port	8	4	8
10/100/1000 TX uplink port	2	2	2
PoE Standard compliant	IEEE802.3af PoE	IEEE802.3af PoE	IEEE802.3af PoE
Vehicle Power Boost Input	DC 12~24V Boost	DC 12~24V Boost	--
PoE Power per port	15.4W	15.4W	15.4W
Total PoE Power Budget	65W*	60W*	65W*
Quality of Service	Yes	Yes	Yes
Fault relay alarm	Yes	Yes	Yes
Aluminum Case Protection	IP31	IP31	IP31
Operating Temperature	-25~60°C	-25~60°C	-25~70°C

\*Specifications may change without prior notice

# 2. Hardware Installation

## 2.1 Hardware Introduction

### Dimensions

JetNet 3810G dimensions: 149.0(H) x 131.2(W) x 66.0(D) (with Din-rail clip)

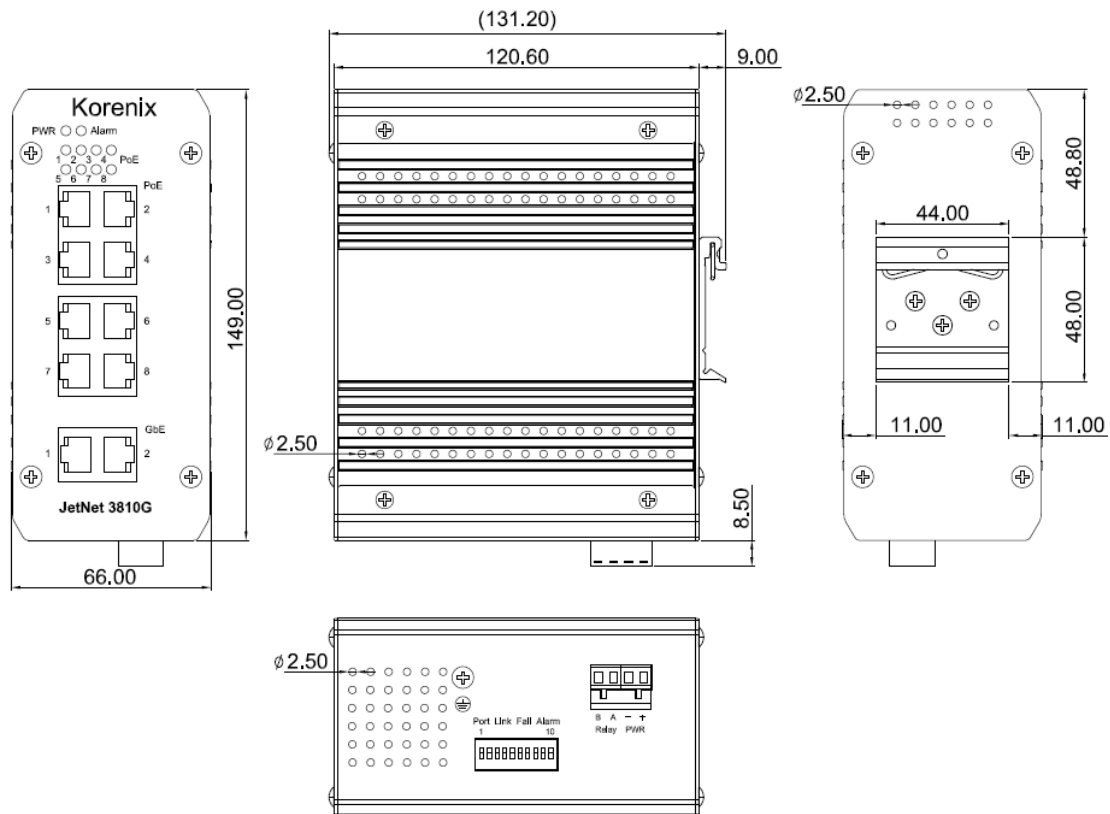

**JetNet 3806G** dimensions: 149.0(H) x 131.2(W) x 66.0(D) (with Din-rail clip)

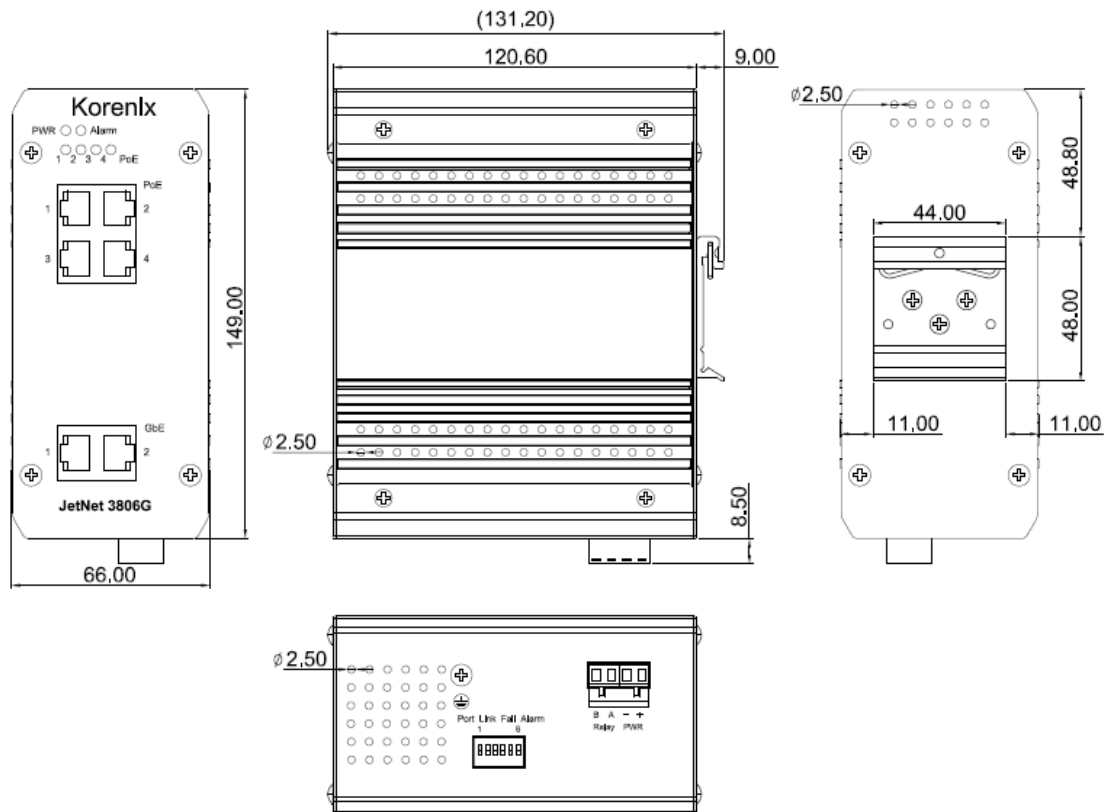

**JetNet 3710G** dimensions: 149.0(H) x 131.2(W) x 66.0(D) (with Din-rail clip)

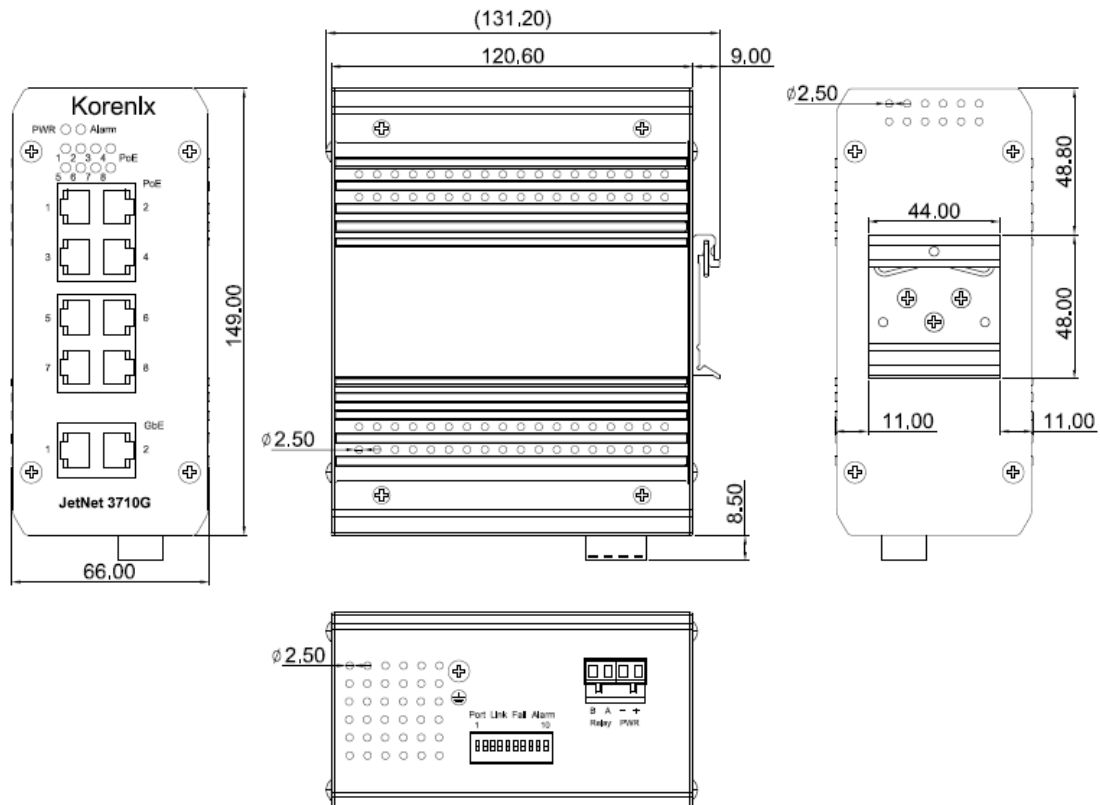

## Front Panel

JetNet 3810G/ 3710G includes system power LED x1, alarm relay LED x1, PoE LED x8; and 20 LEDs for the port operating status.

JetNet 3806G includes system power LED x1, alarm relay LED x1, PoE LED x4, and 12 LEDs for the port operating status.

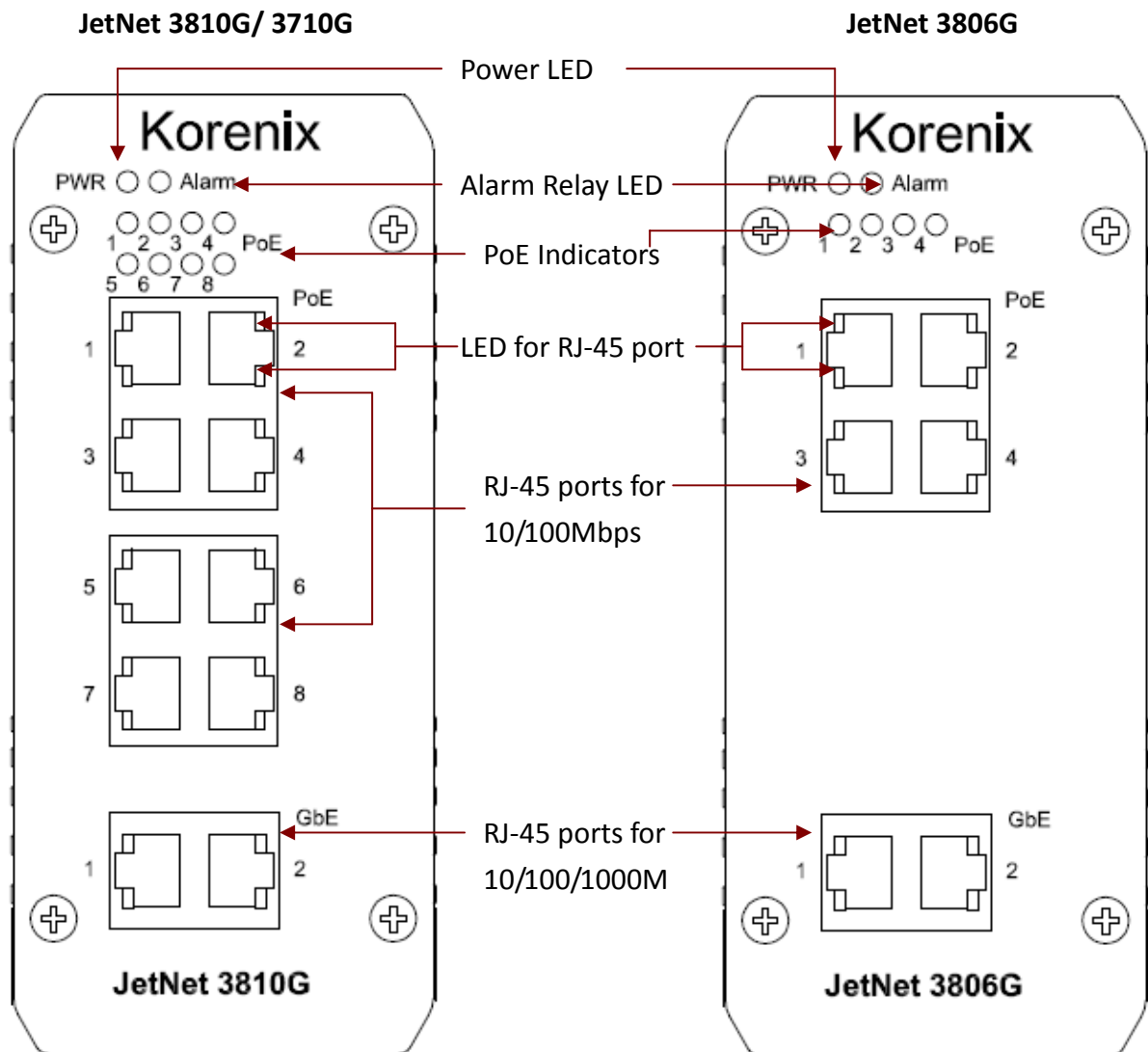

## Bottom View

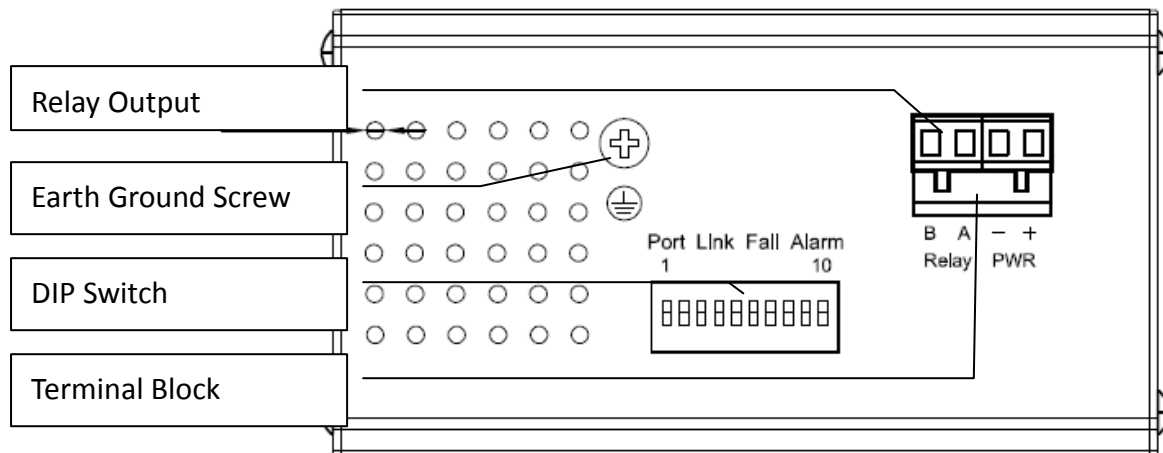

The bottom side of the JetNet 3810G/ 3710G includes one 4-pin removable terminal block connector (with 1 power input & 1 relay alarm output) and one 10-Pin DIP Switch for ports link failure alarm (6-Pin DIP Switch for JetNet 3806G). There is also an earth ground screw to prevent interference.

## LED Indicators

The following table describes the function of each LED indicator.

LED	Status	Description
PWR	Green	DC-IN Power Jack is On
	Off	No Power in DC-IN
Alarm	Red	Ports link failure occur
	Off	No failure is found

PoE LED	Status	Description
PoE 1~8	Green	The port is delivering PoE power.
	Off	No PD is attached.

10/100 TX Port LED	Status	Description
LNK/ACT	Green on	RJ-45 port is attached with partner.
	Blinking	RJ-45 port is transmitting or receiving packets.

	Off	RJ-45port's link is inactive
<b>FDX/COL</b>	Yellow on	Link with partner on Full Duplex mode.
	Blinking	Data collision is occurred.
	off	RJ-45 port's link is inactive or link as Half Duplex mode.

<b>GbE TX Port LED</b>	<b>Status</b>	<b>Description</b>
<b>LNK/ACT</b>	Green on	RJ-45 port is attached with partner.
	Blinking	RJ-45 port is transmitting or receiving packets.
	Off	RJ-45port's link is inactive
<b>Speed</b>	Yellow Blinking	3 blinks per order – 1000Mbps
		2 blinks per order – 100Mbps
		1 blinks per order – 10Mbps
	off	RJ-45 port's link is inactive

## 2.2 Wiring the Power Inputs

JetNet 3810G/3806G is a specific surveillance system used in vehicles. It accepts 12~24V DC power input and boosts to 48V DC output for 802.3af standard PoE devices.

JetNet 3710G without power boosting function accepts only 48V DC power Input.

**IMPORTANT:** Do make sure that different models must connect to the corresponding supply voltage. Guarantee will not apply to the damage caused by wrong input power.

1. Insert the positive and negative wires of your DC supply into the V+ and V- contacts of the terminal block connector. The acceptable wire range is 12 to 24 AWG.

### JetNet 3810G/ 3806G

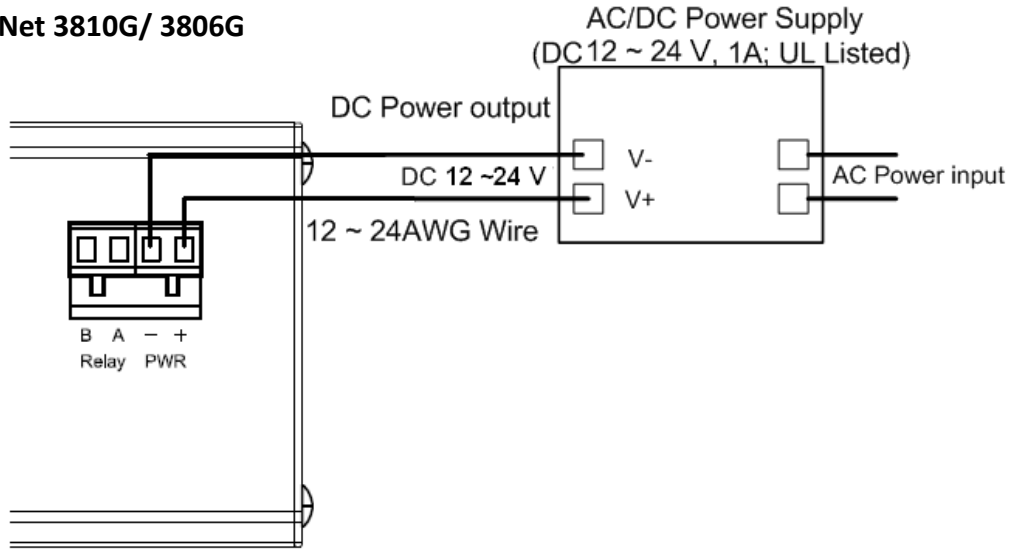

### JetNet 3710G

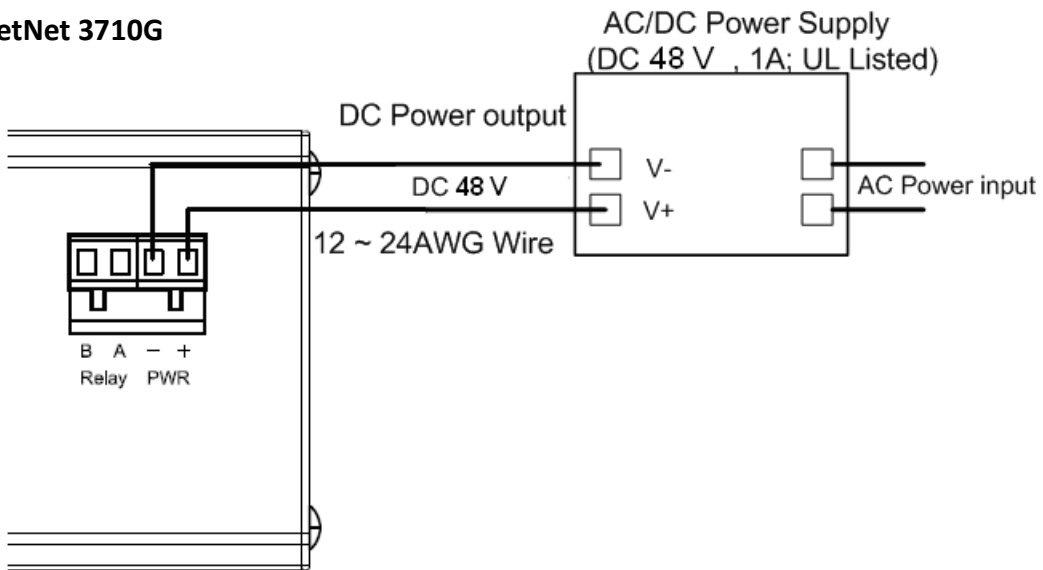

2. Tighten the terminal screws to prevent the DC wires from coming loose.

## 2.3 Wiring the Relay Output

JetNet 3810G/3806G/3710G provide Relay Output. The relay contacts are energized (open) for normal operation and will close under faulty condition such as Ethernet port link break. The Relay alarm can be configured by DIP Switches.

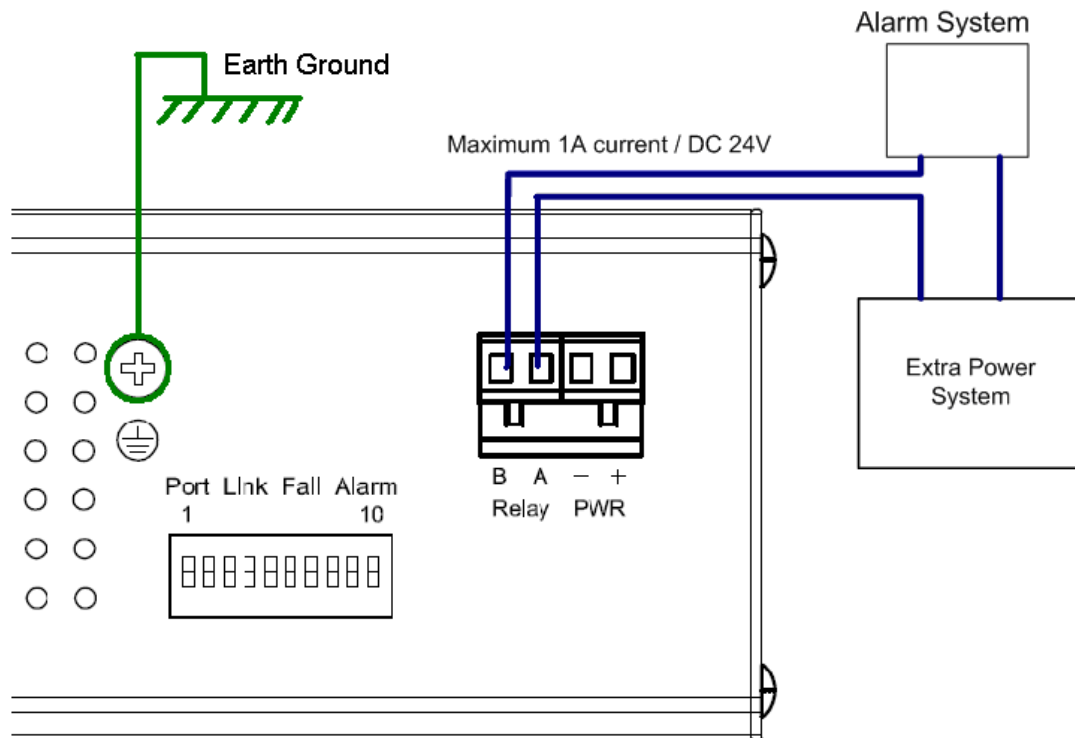

## 2.4 Wiring Earth Ground

To ensure the system will not be damaged by noise or electric shock, we suggest making a direct connection between the JetNet 3810G/3806G/ 3710G and earth ground to avoid system damage. (Please refer to the upside photo)

1. On the bottom of the JetNet 3810G/3806G/ 3710G, there is one earth ground screw.
2. Loosen the earth ground screw with a screwdriver
3. Tighten the screw after the earth ground wire is connected.

## 2.5 DIP Switches

10-Pin Dip switches are located on the bottom panel of JetNet 3810G/ 3710G for configuration purpose (6-Pin for JetNet 3806G). They are used to configure Port Alarm to corresponding TX ports.

DIP Switch number	Status	Description
DIP 1~2 (JetNet 3810G/3710G/ 3806G)	On	To enable GbE port break alarm at this port
	Off	To disable GbE port break alarm at this port (Default)

JetNet 3810G/3710G: DIP 3~10  JetNet 3806G: DIP 3~6	On	To enable PoE port break alarm at this port
	Off	To disable PoE port break alarm at this port (Default)

**Note:** DIP Switch number mapping to corresponding PoE port & GbE port as follow:

DIP Switch #	3	4	5	6	7	8	9	10
PoE port	1	2	3	4	5	6	7	8

DIP Switch #	1	2
GbE port	2	1

## 2.6 Wiring the Ethernet Ports

JetNet 3810G/ 3806G/ 3710G Industrial Gigabit PoE Switch support 8/4 RJ-45 ports with automatic MDI/MDI-X crossover, PoE Injector, and automatic 10/100Mbps data rate sensing for 10Base-T or 100Base-TX connections. Automatic MDI/MDI-X crossover allows you to connect to other switches, hubs, or workstations, without regard to using straight-through or crossover cabling. The switch also provides two 10/100/1000 Base-TX uplinks

Port 1 to port 8/4 also provides Power over Ethernet function that delivers DC 48V power through the spare pairs to power the PD.

The following figures depict the schematic diagram of straight-through and crossover cabling. Note that crossover cables simply cross-connect the transmit lines at each end to the receive lines at the opposite end.

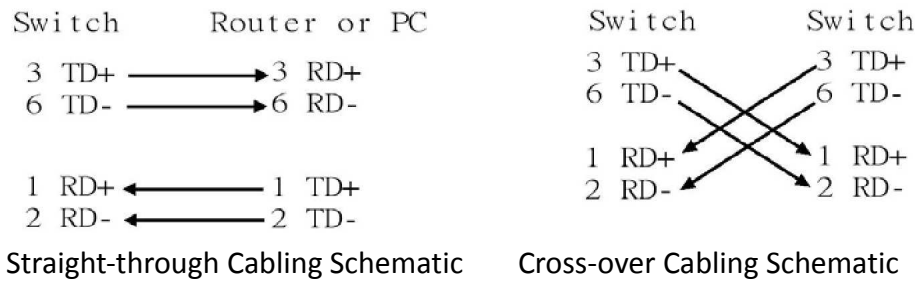

**Note:** that Ethernet cables use pins 1, 2, 3, and 6 of an 8-pin RJ45 connector. The signals of these pins are converted by the automatic MDI-X function, as shown in the table below:

Pin MDI-X	Signals	MDI Signals
1	RD+	TD+
2	RD-	TD-
3	TD+	RD+
6	TD-	RD-

Connect one side of an Ethernet cable into any switch port and connect the other side to your attached device. The green LNK LED will light up when the cable is correctly connected. Refer to the LED Indicators section for descriptions of each LED indicator. Always make sure that the cables between the switches and attached devices (e.g. switch, hub, or workstation) are less than 100 meters (328 feet).

## 2.7 Connecting Powered Device (PD)

Port 1 to port 8/4 provide PoE inject function with maximum 15.4w ability to power up the powered device use the straight or cross-over Ethernet cable.

The JetNet3810G/ 3806G/ 3710G follow the IEEE802.3af Alternative B mode connector assignment. The following table shows pin assignment of alternative A and B for the PSE ( Power Source Equipment).<sub>PSE</sub>

Conductor	Alternative A (MDI-X)	Alternative A (MDI)	Alternative B (All)
1	Rx & Negative Vport	Tx & Positive Vport	
2	Rx & Negative Vport	Tx & Positive Vport	
3	Tx & Positive Vport	Rx & Negative Vport	
4			Positive Vport
5			Positive Vport
6	Tx & Positive Vport	Rx & Negative Vport	
7			Negative Vport
8			Negative Vport

### PIN Assignment of PSE

Be sure the twisted pair cable is bound with the standard RJ-45 pin, especially the pin 4, 5, 7 and 8.

If the RJ-45 is bound with the wrong pin number, JetNet3810G will not recognize the PD and won't forward DC 48V power to PD, since the JetNet 3810G series switch following the Alternative B mode.

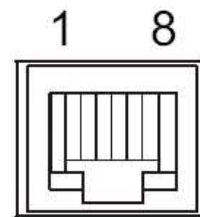

In the IEEE 802.3af standard documents, it indicates the PD should support mode A and B, and only receiver power from either mode A or mode B.

The following table shows the RJ-45 pin out for the PD.

PD Pinout		
Conductor	Mode A	Mode B
1	Positive Vport, Negative Vport	
2	Positive Vport, Negative Vport	
3	Negative Vport, Positive Vport	
4		Positive Vport,
5		Positive Vport,
6	Negative Vport, Positive Vport	
7		Negative Vport,
8		Negative Vport,

## 2.8 DIN-Rail Mounting Installation

The DIN-Rail clip is already attached on the rear side of JetNet 3810G/ 3806G/ 3710G. It supports EN 50022 standard DIN Rail, in the following diagram includes the dimension of EN 50022 DIN Rail for your reference.

**The DIN rail should behind the spring when install the JetNet 3810G series onto the standard DIN Rail.**

Follow the steps below to mount the JetNet 3810G series on the DIN-Rail track.

1. Insert the upper end of the DIN-Rail clip into the back of the DIN-Rail track from its upper side
2. Lightly push the bottom of the DIN-Rail clip into the track.
3. Check if the DIN-Rail clip is tightly attached to the track.

To remove the JetNet 3810G series from the track, reverse the steps above.

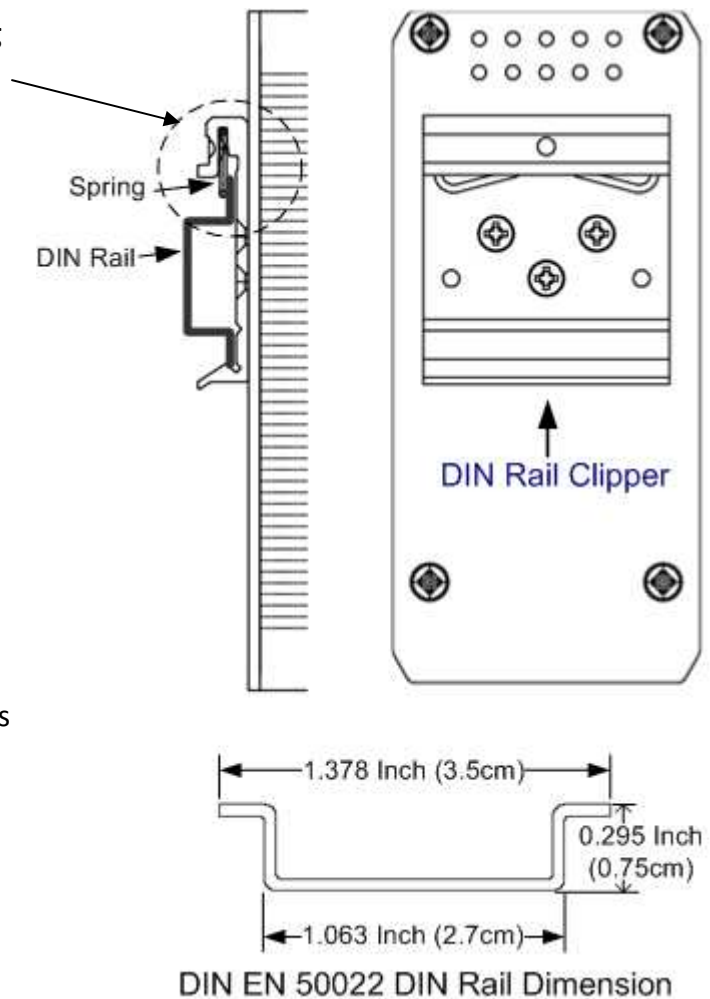

## 3. Appendix

3.1 Product Specification

3.2 Revision History

### 3.1 Product Specification

Technologies	
<b>Standard</b>	IEEE 802.3 10Base-T Ethernet IEEE 802.3u 100Base-T Fast Ethernet IEEE 802.3ab 1000Base-T IEEE802.3x Flow Control and Back-pressure IEEE 802.3af Power Over Ethernet IEEE 802.1p Class of Service
Performance	
<b>Switch Technology</b>	Store and Forward Technology with 32Gbps Switch Fabric.
<b>System Throughput</b>	14,880pps for 10M Ethernet, 148,800pps for 100M Fast Ethernet, 1,488,100pps for Gigabit Ethernet
<b>Transfer packet size</b>	64 bytes to 1522 bytes for untag and tagged frames
<b>MAC Address</b>	8k
<b>Packet Buffer</b>	1 Mbits
<b>MTBF</b>	Greater than 20,000 hours @ 25 °C
Interface	
<b>Configuration</b>	802.3af compliant PoE ports x 8 - JetNet 3810G/ 3710G x 4 - JetNet 3806G  10/100/1000Base-TX x 2 Auto MDI/MDI-X, Auto Negotiation
<b>Cables</b>	10Base-T: 2-pair UTP/STP Cat. 3, 4, 5 cable (100m) 100 Base-TX: 2/4-pair UTP/STP Cat. 5 cable (100m) 1000 Base-T: 4-pair UTP/STP Cat. 5 cable (100m)
<b>Diagnostic LED</b>	Power (Green) x1 Fault alarm (Red) x1 PoE (Green) x8 - JetNet 3810G/ 3710G x4 - JetNet 3806G Link/Activity(Green) x8 - JetNet 3810G/ 3710G

	X4 - JetNet 3806G
	Full duplex/Collision (Yellow) x8 - JetNet 3810G/ 3710G x4 - JetNet 3806G
	Gigabit Copper: Link/Activity(Green) x2
	Gigabit Copper: Speed (Yellow) x2
<b>Relay Alarm</b>	Dry Relay output with 1A@24V ability
<b>POE technology</b>	Alternative B
<b>Power Requirements</b>	
<b>Power</b>	12~24V DC input voltage –JetNet 3810G/ 3806G 48V DC input voltage - JetNet 3710G Isolated 3.3V system power
<b>Power Consumption*</b>	JetNet 3810G/ 3710G: 30 Watt without PoE loading 95 Watt with full PoE loading  JetNet 3806G: 25 Watt without PoE loading 80 Watt with full PoE loading
<b>Mechanical</b>	
<b>Construction</b>	Rugged Aluminum Alloy Chassis, IP31 protection
<b>Mounting</b>	DIN-Rail mount
<b>Dimension</b>	66(W) x 149(H) x 131.2(D) mm (with Din-rail clip)
<b>Net weight</b>	1.05kg
<b>Environment</b>	
<b>Operating Temp</b>	JetNet 3810G/ 3806G -13 ~ 140°F(-25 ~ 60°C), 5 to 95% RH  JetNet 3710G -13 ~ 158°F(-25 ~ 70°C), 5 to 95% RH
<b>Storage Temp</b>	-40 ~ 176°F(-40 ~ 80°C), 5 to 95% RH
<b>Railway**</b>	EN50155
<b>EMC</b>	<b>EMI:</b> FCC class A, CE/EN55022 Class A <b>EMC:</b> EN61000-4-2, EN61000-4-3, EN61000-4-4, EN61000-4-5, EN61000-4-6, EN61000-4-8, EN61000-4-11 <b>Shock:</b> IEC60068-2-27 (50g peak acceleration) <b>Vibration:</b> IEC60068-2-6 (5g/ 5~500Hz/random operation)
<b>Warranty</b>	5 years

\*Specifications may change without prior notice

\*\*pending

## 3.2 Revision History

<b>Edition</b>	<b>Date</b>	<b>Modifications</b>
V0.1	06/30/2010	New edition