

JetWave Series Outdoor IEEE 802.11 a/b/g/n Industrial Wireless AP

With wireless becoming a preferred method of communication and networking, and with the new devices making mobile data more usable, there is a growing interest in increasing its usage in the outdoor industrial environments. Korenix introduces a complete solution of long and mid-range wireless outdoor Access Points for flexible unwired network constructions in harbors, railways, public utilities, mining areas and other outdoor environments. Korenix's wide range of Wireless Networking Devices are compliant with IEEE 802.11 a/b/g/n standards to perfectly fit your specific application needs.

IEEE 802.11 a/b/g/n for Flexible Applications

The right wireless networking standard can provide significant advantages. Therefore, when choosing a WLAN standard, many aspects need to be considered.

The table in left shows a brief comparison of the main distinctive features of the IEEE 802.11 standards:

	802.11	802.11a	802.11b	802.11g	802.11n
Standard	July 1997	Sept 1999	Sept 1999	June 2003	2009
Bandwidth	83.5 MHz	300 MHz	83.5 MHz	83.5 MHz	83.5 MHz w / 2.4 GHz 600 MHz w / 5.0 GHz
Frequencies	2.4 GHz	5.8GHz	2.4 GHz	2.4 GHz	2.4 GHz / 5.8GHz
Non-overlapping Channels	3	4 Indoor 4 Indoor/Outdoor 4 Outdoor	3	3	13-20 MHz on 2.4 GHz 23-20 MHz on 5.0 GHz 11-40 MHz on 5.0 GHz
Maximum Data Rates	2 MHz	54 MHz	11 MHz	54 MHz	300 MHz on 20 GHz Channels 600 MHz on 40 GHz Channels

Which JetWave to Choose

Korenix JetWave 2600 & JetWave 2400 series are multi-standardized wireless devices designed to provide high performance data at your desired speed, size and to your desired distance.

JetWave 2600 Series Industrial Wireless Outdoor Access Point is an ideal solution for industrial networks seeking to extend wireless signal coverage to up to 40KM. JetWave 2600 series implements IEEE 802.11a technology, using 5.8GHz band as the operating frequency. In addition, JetWave 2640 model adopts dual band IEEE 802.11a and 802.11b/g solutions for easily relaying data from wireless devices to long-distance monitoring sites. JetWave 2450 series Industrial Wireless Outdoor AP is a high cost/performance ratio solution perfect fit for unwired data transmission in mid-range applications. Compliant with 802.11b/g/n standards,

JetWave 2450 series delivers high output power and high sensitivity and, therefore extends range and coverage for providing stable wireless connection while reducing the roaming between APs. The JetWave 2450 supports the newest ratified IEEE 802.11n standard, and features 3 times higher data rate than 802.11b/g standard, targeting to reach 60~80Mbps outstanding performance and, thus to meet user expectations for next-generation's mobility.

		802.11a	802.11b	802.11g	802.11n
Long Range 40KM	JetWave 2610	•			
	JetWave 2620	Dual			
	JetWave 2640	•	•	•	
Mid Range 5KM	JetWave 2450		•	•	•

- All product specifications are subject to change without further notice.
- Before applying to critical projects, please contact Korenix headquarter for up-to-date product specifications' consultancy.

Industrial Intelligent NMS

Rackmount PoE Plus Switch

Industrial PoE Plus Switch

Industrial 12-24V PoE Switch

Industrial PoE Switch

Rackmount L3/L2 Switch

Gigabit Managed Switch

Managed Ethernet Switch

Entry-level Switch

Wireless Outdoor AP

Embedded PoE/Router Computer (LINUX)

Industrial Communication Computer (WIN/LINUX)

Ethernet/PoE/ Serial Board

Ethernet I/O Server

Media Converter

Serial Device Server

SFP Module

Din Rail Power Supply

Multiple Wireless Network Configurations for Ease of Use

Devices in a wireless network are set up to either communicate indirectly through a central place (Infrastructure Mode) or directly - peer to peer without intermediate devices (Ad-hoc Mode). However, each of these modes has its advantages and disadvantages when it comes to the scalability, improved reach, cost-

effectiveness, etc. Korenix JetWave Series support multiple wireless direct and indirect operation modes, including base station (AP), CPE, Relay, Point to Point, Point to Multiple Point modes to offer users the flexibility of choosing the best wireless configuration for their specific application requirements.

High Gain Antennas to Improve Signal Quality & Enlarge Coverage

JWA-5.8G-23dBi	Directional Panel Antenna 23dBi
JWA-5.8G-15dBi	Sector-Directional Antenna 15dBi
JWA-2.4G-15dBi	Omni-Directional Antenna 15dBi
JWA-2.4G-12dBi	Sector-Directional Antenna 12dBi
JWA-2.4G-9dBi	Omni-Directional Antenna 9dBi
JWA-2.4G-5dBi	Omni-Directional Antenna 5dBi
JWA-Arrestor-5803	0-6G Arrestor for N-Type Antenna

To provide more flexibility to wireless users while deploying JetWave series, Korenix offers various wireless antennas, which ensure the reliability and the high quality of data transmission in harsh environments.

Encrypted Wireless Data Transmission

Unlike wired LAN, in which unauthorized access can be easily identified by the physical media, Wireless LAN does not have the same physical media protection and is difficult to block the illegal access. Technologies, such as Wired Equivalent Privacy (WEP) and WPA 1/2 (Wi-Fi Protected Access version 1 and

2) are designed to provide the same level of security by encrypting data over radio waves from hosts to the Access Point (AP) or WEP/WPA-enabled stations and hosts. Korenix JetWave series use WEP, WPA and WPA2 high level wireless security standards to provide secure data transmission over wireless network.

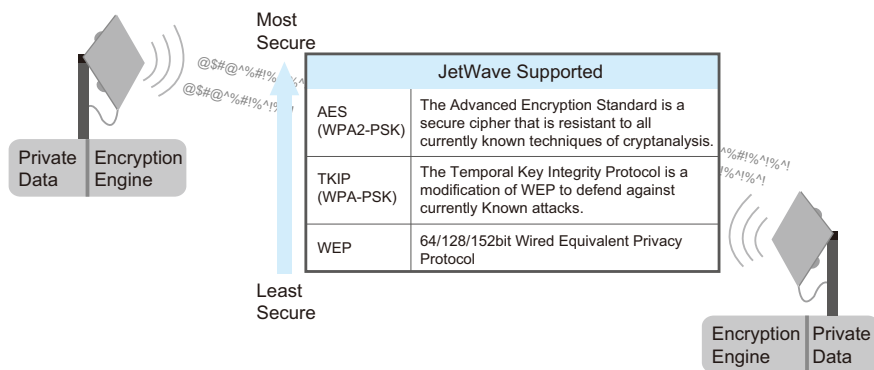

WMM (QoS) for Optimal Wireless Video Surveillance

JetWave series supports WMM (Wi-Fi Multimedia) technology, which allows the wireless communication to give the highest priority to multimedia streaming:

the video stream is given precedence over data packets and is delivered more efficiently even under limited bandwidth.

Integrated PoE Technology for Power Unreachable Destinations

JetWave 2600 Series integrates IEEE 802.3af Power over Ethernet (PoE) technology, that allows installation of the device in power unreachable locations. Moreover, being compatible with Korenix PoE switches, the APs

can be used with Korenix JetPoE and JetBox series for providing total solutions for highways, railways, dams, mines, harbors, wind power stations, etc.

Ruggedized Design for Extreme Outdoor Deployment

JetWave 2600 series features rugged mechanical design, including IP67 grade protection, level 17 Beaufort scale and -30°C to +70°C wide operating temperature

to withstand water, wind and other severe weather conditions in outdoor environments while providing real-time and high quality wireless data transmission.

Intel® TDMA Enlarges Coverage and Performance

JetWave 2600 series supports different types of Wireless Multiple Access technologies, including CSMA and Intel® TDMA for various distance applications. CSMA is the abbreviation of Carrier Sense Multiple Access, and is widely applied in Ethernet LAN and WLAN applications. However, its performance drops dramatically, when the transmission distance increases.

To achieve longer distances with higher bandwidth, Korenix adopts Intel® TDMA technology as well. Customers can setup CSMA or TDMA locally depending on the transmission distance. With a default 23dBi panel antenna, the wireless extensibility can reach at least 40KM with guaranteed transmission quality.

Outdoor AP Technology	Uplink/Downlink (Mbps)	Uplink + Downlink (Mbps)
20km (CSMA)	13.139/13.426	12.044
20km (TDMA)	13.155/20.125	19.168
40km (CSMA)	N/A	N/A
40km (TDMA)	28.836/16.527	21.073

Link Aggregation Performance

JetWave 2620 adapts dual 802.11a modules for users to aggregate the radio. The link aggregation technology doubles the throughput of point to point application while directly relaying the traffic without any loss. JetWave 2620 can be set as Relay Mode for two devices

to be connected without damaging performance. With dual 5.8GHz modules, it is the ideal backhaul solution for outdoor AP applications, especially for long-distance transportation, utility, and other critical environmental applications.

Outdoor AP Technology	Uplink/Downlink (Mbps)	Uplink + Downlink (Mbps)
20km (CSMA)	13.139/13.426	12.044
20km (CSMA+Link Aggregation)	22.593/23.503	36.508

Industrial
Intelligent
NMS

Rackmount
PoE Plus
Switch

Industrial
PoE Plus
Switch

Industrial
12-24V
PoE Switch

Industrial
PoE Switch

Rackmount
L3/L2 Switch

Gigabit
Managed
Switch

Managed
Ethernet
Switch

Entry-level
Switch

**Wireless
Outdoor AP**

Embedded
PoE/Router
Computer
(LINUX)

Industrial
Communication
Computer
(WIN/LINUX)

Ethernet/PoE/
Serial Board

Ethernet
I/O Server

Media
Converter

Serial Device
Server

SFP Module

Din Rail
Power Supply

Wireless Subway Monitoring System

High Performance and Real-Time Wireless Connectivity



For high-performance and reliable transportation network construction, optimization of subway infrastructure and train communication equipment are required. In order to provide safety feeling to passengers, advanced monitoring systems integrate intelligent embedded wireless networking solutions inside carriages and aboard the trains. With current technological developments, higher data rate communication is needed to be transferred within limited time frames, hereafter the WLAN systems with high-performance, reliable and fast connection fulfill main requirements of communication-based train control systems.

Korenix wireless and wired networking solutions have been integrated inside the train and in each subway station to provide real-time monitoring and control of the carriages.

Users are able to collect all the captured video images in the carriages via the 5 rugged M12 ports of the JetNet 2006-M12 switches and using the last port, uplink all the information to the NVR system. Due to their rugged design and the M12 connectors, the switches can easily resist vibration and shock in moving vehicles, and provide reliable data transmission becoming the best solutions for data collection.

Using the built-in Ethernet interface, the JetWave 2450 Wireless Access points later collect the video images from the NVR and through 802.11n Wireless N band connect and communicate the controlled video data to another JetWave 2450 installed in each subway station.

With software changeable antenna design, system integrators can easily choose the omni antenna through the N type socket for extending transmission up to 5km by overlaying multiple radio signals. Subway station administrators can greatly benefit from the 802.11n technology of the Wireless devices, to transfer up to 100M high-bandwidth video and other data from the train within 30 seconds during a short stop at the train station.

To protect data and privacy, various advanced security features, such as WEP, WPA and WPA2 are used for encoding all wireless transmissions with powerful encryption. The MAC Address filter further provides secure access to the wireless network. For further ensuring high quality of the communication, the JetWave series support spanning tree protocol to avoid loop storm, WMM (QoS) to prioritize classes for different applications, IGMP snooping for multicast stream filtering and NTP for network time synchronization. In addition to all these advanced functionalities, the wireless APs feature IP55 design and wide operating temperature to reliably perform under extreme environments. With all the advanced features, Korenix JetWave 2450 and JetNet 2006-M12 become ideal reliable and cost-effective solutions for ensuring real-time and high-performance wireless surveillance of modern subway systems.

Why JetWave 2450

- Average 60~70Mbps data throughput; Up to 100Mb video data can be transmitted to control room within 30 seconds through IEEE802.11n band.
- Cost-effective: Triple times higher performance than 802.11b/g and low maintaining cost for the video surveillance network
- One model with both Embedded 8dbi Directional Antenna and N-Type Socket for ensuring video stream transmission and simultaneously providing Wireless Service to passengers
- Up to 5KM Wireless coverage
- IP55 design and -20~70°C operating temperature

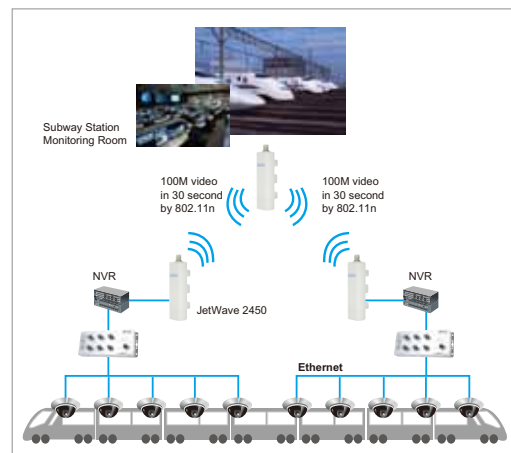

Korenix Product Selection Guide – Outdoor Wireless AP/Bridge

Wireless Outdoor AP



JetWave 2610



JetWave 2620



JetWave 2640



JetWave 2450

	Wireless Outdoor AP	Dual 5.8G Wireless Outdoor AP	Dual Band Wireless Outdoor AP	802.11b/g/n Wireless Outdoor AP
Interface				
Number of 10/100 Ports	1	1	1	1
Number of WLAN Ports	1	2	2	1
Standard	802.11a	802.11a	802.11a + 802.11b/g	802.11n (802.11b/g compliant)
Maximum Transmission Distance		40KM		5KM
Operating Frequency		FCC : 2.412~2.462GHz, 5.725~5.850 GHz CE : 2.412~2.472GHz, 5.470~5.600 GHz, 5.650~5.725 GHz		FCC: 2.412 ~2.462 GHz(HT20), 2.422~ 2.452 GHz(HT40) CE/ETSI: 2.412 ~ 2.472 GHz(HT20), 2.422~ 2.462 GHz(HT40)
RF Output Power		802.11a: 24dBm/FCC; 30dB/CE 802.11b/g: 23dBm/FCC; 20dB/CE		FCC: 802.11b/g/n: Max. 27.5dBm ETSI(CE): 802.11b/g/n: Max. 10.5dBm
RX Sensitivity		802.11a: ≤ -92dBm@6Mbps; ≤ -73dBm@54Mbps 802.11b/g: -96dBm@1Mbps; -90dBm@6Mbps; -72dBm@54Mbps		802.11b: 11Mbps ≤ -93dBm 802.11g: 54Mbps ≤ -88dBm 802.11n - HT 20 ≤ -88dBm 802.11n - HT 40 ≤ -84dBm
Power Input (PoE)	802.3af (48VDC)	802.3af (48VDC)	802.3af (48VDC)	12V PoE
Buzzer	•	•	•	
Mechanical				
Housing (IP Rating)	IP67	IP67	IP67	IP55
Antenna	1 embedded	1 embedded, 1 external	1 embedded, 1 external	1 embedded/external
Antenna Gain	23dBi Directional	23dBi Directional	11a: 23dBi Directional, 11g: optional	Embedded: 8dbi Directional External: optional (Switched by Software)
Vent	•	•	•	
Dimension (Unit=mm)	400 x 400 x 88(D)	400 x 400 x 88(D)	400 x 400 x 88(D)	165(H) x 60(W) x 34(D)
Operating Temperature	-30~70°C	-30~70°C	-30~70°C	-20~70°C
Protocols				
CLI/Web/Utility Configuration	•	•	•	•
Operating Mode	Base Station, CPE, P2P, P2MP	Base Station, CPE, Relay, P2P, P2MP	Base Station, CPE, P2P, P2MP	Base Station, CPE, P2P, P2MP
CSMA	•	•	•	•
Intel TDMA	•	•	•	
Super A/G	•	•	•	
Link Aggregation	•	•		
STP (Spanning Tree Protocol)	•	•	•	•
Link Test Tools	•	•	•	•
Encryption - WEP	•	•	•	•
Encryption - WPA, WPA2	•	•	•	•
HTTPS, SSH	•	•	•	•
802.1x, MAC Access Control	•	•	•	•
Wireless Isolation	•	•	•	•
QoS (WMM)	•	•	•	•
Others				IGMP Snooping, DHCP Server, Router mode
Certification				
Regulatory Approval: CE/FCC	•	•	•	•
RoHS/WEEE	•	•	•	•



JetWave 2600 Series

Wireless Outdoor AP / Bridge



Overview

JetWave 2600 Series Industrial Wireless Outdoor Access Point is an ideal solution for industrial networks seeking to extend wireless signal coverage. JetWave 2600 series implements 802.11a technology, using 5.8GHz band as the operating frequency. JetWave 2610 adopts IEEE 802.11a solution, JetWave 2620 adopts dual IEEE 802.11a solution and JetWave 2640 adopts dual band IEEE 802.11a and 802.11b/g solutions. The wireless operation mode supports base station (AP), CPE, Relay and point to point and point to multiple point modes. Comprehensive wireless security is implemented by

the WEP, WPA and WPA2 encryptions in JetWave 2600 series.

JetWave 2600 Series has a built-in 23dBi directional panel antenna that can transmit signals to at least 40KM distance. An external antenna can be used to improve signal quality and enlarge coverage. The PoE design allows the JetWave 2600 series to be easily powered by PSE device, such as JetPoE, Korenix Industrial PoE switches, as the total solution. For outdoor installation, JetWave 2600 series feature IP67 rugged mechanical design with -30 to 70°C operating temperature.

JetWave 2600 Series include:

JetWave 2610 IEEE802.11a Wireless Outdoor AP/Bridge

JetWave 2620 Dual IEEE802.11a Wireless Outdoor AP/Bridge

JetWave 2640 IEEE802.11a and 802.11b/g Wireless Outdoor AP/Bridge

Benefit of choosing JetWave 2600 Series

Consideration	Benefit of JetWave
WLAN Advantage	802.11a 5.8GHz band with lower interference Dual Band solution to cover both 802.11a and 802.11b/g application Built-in 23dbi panel antenna with high gain capability Intel TDMA technology to enlarge the coverage and performance Operating mode supports Base Station, CPE, Bridge/Relay, Point to Point and Point to Multiple Point
Rugged Design	IP67 Waterproof Vent design to exclude moisture -30~70°C operating temperature Aluminum Pole Mounting Kit
Fully Management Features	Management by Console, Utility, HTTPS, SSH and SNMP Highly Security Feature include WEP/WPA/WPA2 Encryption Authenticated access by 802.1x and MAC access table Management tool to provide group firmware upgrade
Power Supply by Standard PoE	Shipped with PoE injector Fully compatible with Korenix JetPoE product Bundled Outdoor AP Solution

- Industrial Intelligent NMS
- Rackmount PoE Plus Switch
- Industrial PoE Plus Switch
- Industrial 12-24V PoE Switch
- Industrial PoE Switch
- Rackmount L3/L2 Switch
- Gigabit Managed Switch
- Managed Ethernet Switch
- Entry-level Switch
- Wireless Outdoor AP**
- Embedded PoE/Router Computer (LINUX)
- Industrial Communication Computer (WIN/LINUX)
- Ethernet/PoE/Serial Board
- Ethernet I/O Server
- Media Converter
- Serial Device Server
- SFP Module
- Din Rail Power Supply

TDMA Enlarged the Coverage and Performance

JetWave 2600 series supports different types of Wireless Multiple Access technologies, including CSMA and Intel TDMA. CSMA is the abbreviation of Carrier Sense Multiple Access, and is widely applied in Ethernet LAN and WLAN applications. To achieve longer distances with higher bandwidth,

Korenix adopts Intel TDMA technology so customers can setup CSMA or TDMA locally depending on the transmission distance. With a default 23dBi panel antenna, the wireless extensibility can reach at least 40KM with guaranteed transmission quality.

JetWave	Uplink/Downlink (Mbps)	Uplink + Downlink (Mbps)
10km (CSMA)	15.38/15.78	15.81
10km (TDMA)	10.17/8.25	11.25
40km (CSMA)	0.2	Ping only
40km (TDMA)	6.14/ n/a	8.54

High Performance Transmission

There are several types of 802.11 Standards. IEEE 802.11a uses 5.8GHz band, while 802.11b/g uses 2.4GHz band. The 2.4GHz band is more widely accepted in homes, enterprises, and hotspots and along with a variety of other products, including microwave ovens and cordless phones. The 5.8GHz band is less popular, so there is less congestion to cause interference or signal contention.

For long distance WLAN AP, to extend transmission and achieve higher performance, less interference indicates higher coverage and more highly scalable and flexible installation. Therefore Korenix recommends 802.11a as the Wireless Outdoor Access Point solution. Besides the 802.11a model, Korenix also provides dual band model which supports both 2.4GHz and 5.8GHz to cover most of the applications.

Attribute	802.11b/g	802.11a
Frequency	Crowded 2.4GHz	Un-crowded 5GHz
In-band Noise	<ul style="list-style-type: none"> ■ Devices such as microwaves, cordless phones... ■ Other nearby WLAN ■ Few non-overlapping channels lead interference easier 	<ul style="list-style-type: none"> ■ Some cordless phone transmit at 5GHz in one direction ■ 24 non-overlapping channels can segregate traffic
Popularity	Homes, Enterprise, hotspot; PC/NB embedded	Enterprise access point, long distance outdoor AP with high gain antenna
Selection Consideration	Reflection, wall penetration, how fast the channel changes Maturity, Popular, low per-station pricing, high interoperability	<ul style="list-style-type: none"> ■ Low interference environment ■ Directional or omni antenna ■ Some countries do not formally open the band

Link Aggregation Performance

JetWave 2620 adopts dual IEEE802.11a modules for users to aggregate the radio. The link aggregation technology doubles the throughput of point to point application. JetWave 2620 can be set as Relay Mode for two devices to be connected without

damaging performance. The JetWave 2620 is the ideal backhaul solution for outdoor AP application, especially for long-distance transportation, utility, and critical environmental applications.

JetWave	Uplink/Downlink (Mbps)	Uplink + Downlink (Mbps)
10km (CSMA)	15.38/15.78	15.81
10km (CSMA + Link Aggregation)	19.7 / 18.89	21.68

Encrypted Wireless Data Transmission

Unlike wired LAN, where unauthorized access can be easily identified by the physical media, Wireless LAN does not have the same physical media protection and is difficult to block the illegal access. Technologies such as Wired Equivalent

Privacy(WEP) and WPA 1 / 2 (Wi-Fi Protected Access version 1 and 2) are designed to provide the same level of security by encrypting data over radio waves from hosts to the Access Point (AP) or WEP/WPA-enabled stations and hosts.

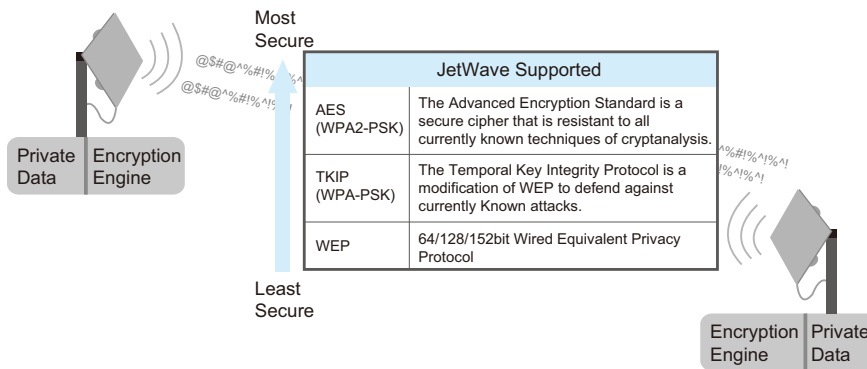

- Industrial Intelligent NMS
- Rackmount PoE Plus Switch
- Industrial PoE Plus Switch
- Industrial 12-24V PoE Switch
- Industrial PoE Switch
- Rackmount L3/L2 Switch
- Gigabit Managed Switch
- Managed Ethernet Switch
- Entry-level Switch
- Wireless Outdoor AP**
- Embedded PoE/Router Computer (LINUX)
- Industrial Communication Computer (WIN/LINUX)
- Ethernet/PoE/ Serial Board
- Ethernet I/O Server
- Media Converter
- Serial Device Server
- SFP Module
- Din Rail Power Supply

Power By PoE (Power Over Ethernet)

Power By PSE

Connect the JetWave to the PoE port of the PoE Switch. The clients of the LAN can communicate with remote clients via JetWave AP.

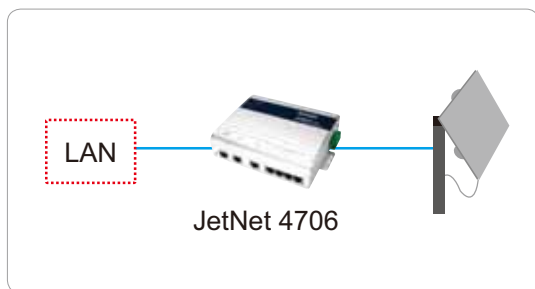

Power by PoE Injector

In case there is no PoE switch on hand, user can connect the AP to the enclosure PoE injector. It can deliver up to 19W power source.

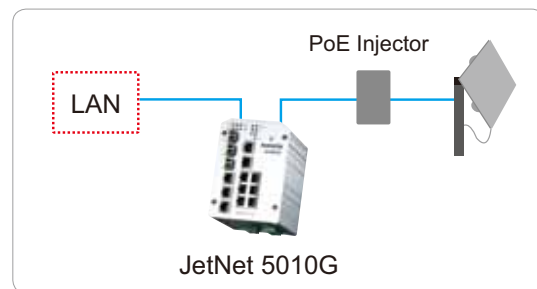

JetWave 2610

Outdoor Long Range IEEE802.11a Wireless AP



CE RoHS

802.11a	Intel TDMA	Built-in 23dBi Antenna	40KM
WMM	IP 67	-30~70°C	

- Supports IEEE 802.11a 5.8GHz band
- Up to 54Mbps maximum net data rate
- High Gain 23dBi Panel Antenna maximizes transmission distance up to 40KM
- Wireless QoS (WMM) for video precedence transmission
- Supports Base Station, CPE, Point to Point and Point to Multiple Point Connectivity
- Intel TDMA Technology for long distance connectivity
- Multiple Data Encryption algorithms, including WEP,WPA,WPA2
- Secured Access Control by HTTPS, SSH, 802.1x, MAC
- Auto ACK-Time adjustment, Link test for easy installation
- Rugged IP67 Protection Housing for outdoor installation
- Power supply compatible with PoE Source
- -30~70°C operating temperature for hazardous environment application

Installation

JetWave 2610 supports one 802.11a interface and embedded 23dbi external antenna which allows users to transmit the traffic through the air. The maximum transmission distance is less than 40KM when running Intel TDMA access mode.

The typical installation is that the 2 JetWave 2610 can communicate directly in a point to point topology. The popular applications include: Long Distance Transportation, Building to Building, and Island to Island.

Base Station and CPE

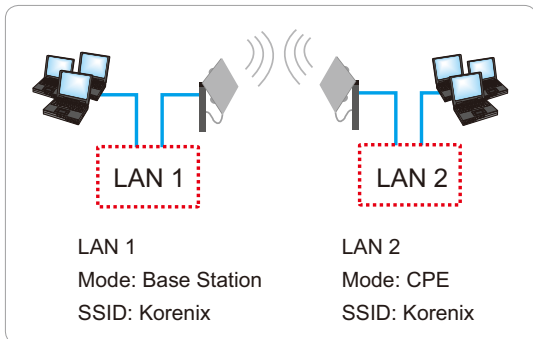

Point to Point mode

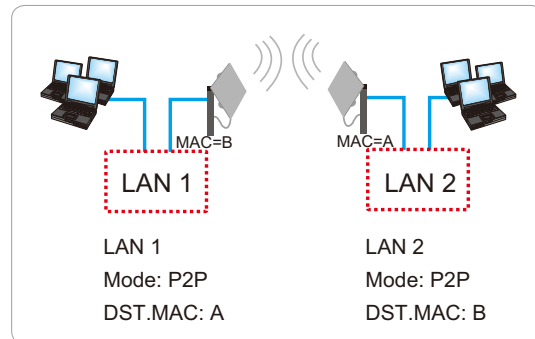

JetWave 2620

Outdoor Long Range Dual IEEE802.11a Wireless AP



CE RoHS

- Dual 802.11a
- Intel TDMA
- Link Aggregation
- Built-in 23dBi Antenna
- 40KM
- WMM
- IP 67
- 30~70°C

- Supports Dual IEEE 802.11a 5.8GHz band
- Up to 54Mbps maximum net data rate
- High Gain 23dBi Panel Antenna maximizes transmission distance up to 40KM
- Link Aggregation allow higher bandwidth for long distance transmission
- Wireless QoS (WMM) for video precedence transmission
- Supports Base Station, CPE, Point to Point and Point to Multiple Point Connectivity
- Intel TDMA Technology for long distance connectivity
- Multiple Data Encryption algorithms, including WEP,WPA,WPA2
- Secured Access Control by HTTPS, SSH, 802.1x, MAC
- Auto ACK-Time adjustment, Link test for easy installation
- Rugged IP67 Protection Housing for outdoor installation
- Power supply compatible with PoE Source
- -30~70°C operating temperature for hazardous environment application

- Industrial Intelligent NMS
- Rackmount PoE Plus Switch
- Industrial PoE Plus Switch
- Industrial 12-24V PoE Switch
- Industrial PoE Switch
- Rackmount L3/L2 Switch
- Gigabit Managed Switch
- Managed Ethernet Switch
- Entry-level Switch
- Wireless Outdoor AP**
- Embedded PoE/Router Computer (LINUX)
- Industrial Communication Computer (WIN/LINUX)
- Ethernet/PoE/Serial Board
- Ethernet I/O Server
- Media Converter
- Serial Device Server
- SFP Module
- Din Rail Power Supply

Installation

JetWave 2620 supports dual 802.11a interfaces, one panel antenna and an external antenna interface. The optional antenna allows users to transmit traffic for different directions or aggregate the 2 wireless interfaces to enhance performance.

The typical installation is that the JetWave 2620 supports link aggregation to enlarge the bandwidth, directly relays traffic without lost, and works as the intermediate Access Point in the long distance transmission application.

Link Aggregation

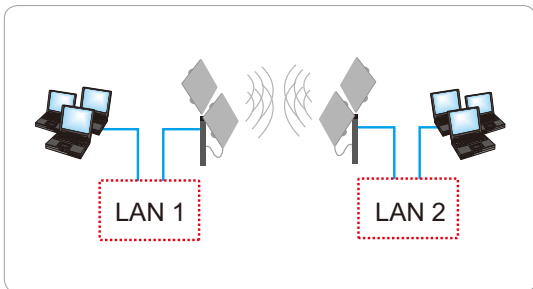

Relay

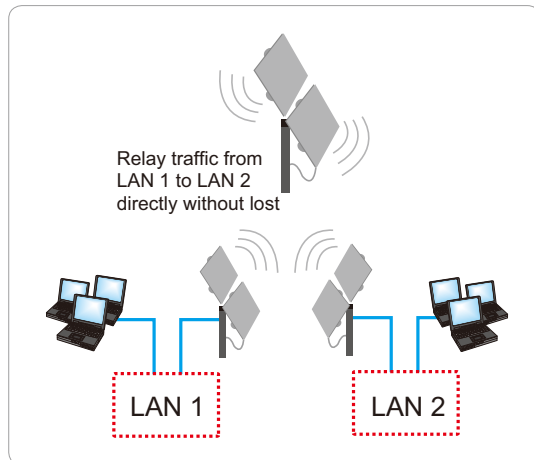

JetWave 2640

Outdoor Long Range Dual Band IEEE802.11a + 802.11b/g Wireless AP



CE RoHS

- 802.11 a/b/g
- Intel TDMA
- Built-in 23dBi Antenna
- Ext. N type Antenna
- 40KM
- WMM
- IP 67
- 30~70°C

- Supports both IEEE 802.11a 5.8GHz and 802.11b/g 2.4GHz band
- Up to 54Mbps maximum net data rate
- High Gain 23dBi Panel Antenna maximizes transmission distance up to 40KM
- N type external Antenna slot
- Wireless QoS (WMM) for video precedence transmission
- Supports Base Station, CPE, Point to Point and Point to Multiple Point Connectivity
- Intel TDMA Technology for long distance connectivity
- Multiple Data Encryption algorithms, including WEP,WPA,WPA2
- Secured Access Control by HTTPS, SSH, 802.1x, MAC
- Auto ACK-Time adjustment, Link test for easy installation
- Rugged IP67 Protection Housing for outdoor installation
- Power supply compatible with PoE Source
- -30~70°C operating temperature for hazardous environment application

Installation

JetWave 2640 supports one 802.11a and one 802.11b/g interface, one panel antenna and an external antenna interface for 802.11b/g band. The optional antenna allows users to transmit data to clients directly.

With the JetWave 2640, users do not need to purchase additional 802.11b/g AP since most CPE(clients) are already embedded with 802.11b/g NIC. The dual band design is suitable for the first or last AP of the long distance transmission.

JetWave without Dual Band

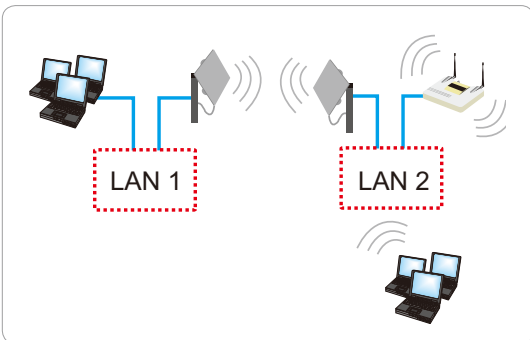

JetWave 2640 Dual Band

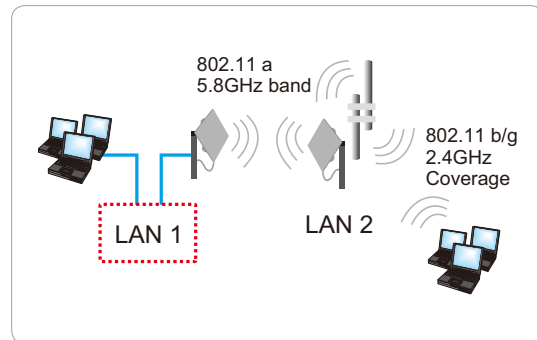

JetWave Application – Typical Outdoor AP Solution

- Base Station and CPE Communication
- P2P using Bridge or Relay Feature

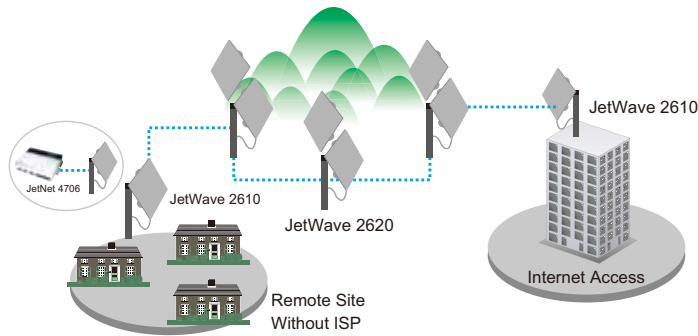

- Industrial Intelligent NMS
- Rackmount PoE Plus Switch
- Industrial PoE Plus Switch
- Industrial 12-24V PoE Switch
- Industrial PoE Switch
- Rackmount L3/L2 Switch
- Gigabit Managed Switch
- Managed Ethernet Switch
- Entry-level Switch

JetWave Application – Dual Band Outdoor AP Solution

- Support both 802.11a and 802.11b/g
- Tunnel/Road site Transportation

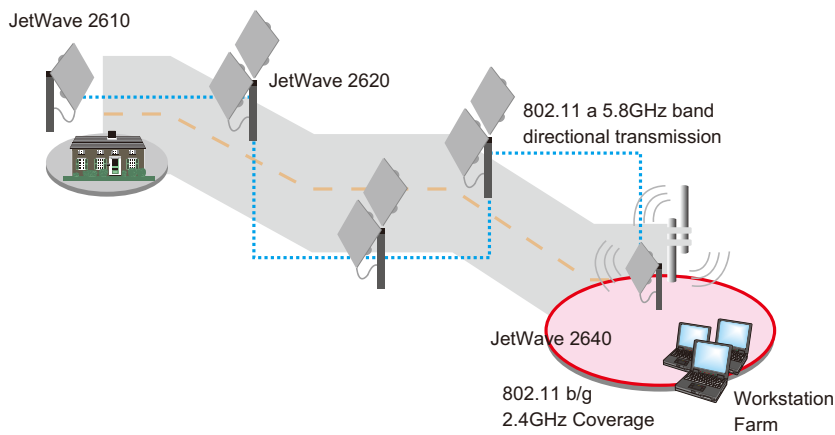

- Wireless Outdoor AP**
- Embedded PoE/Router Computer (LINUX)
- Industrial Communication Computer (WIN/LINUX)
- Ethernet/PoE/Serial Board
- Ethernet I/O Server
- Media Converter
- Serial Device Server
- SFP Module
- Din Rail Power Supply

JetWave 2600 Series Appearance

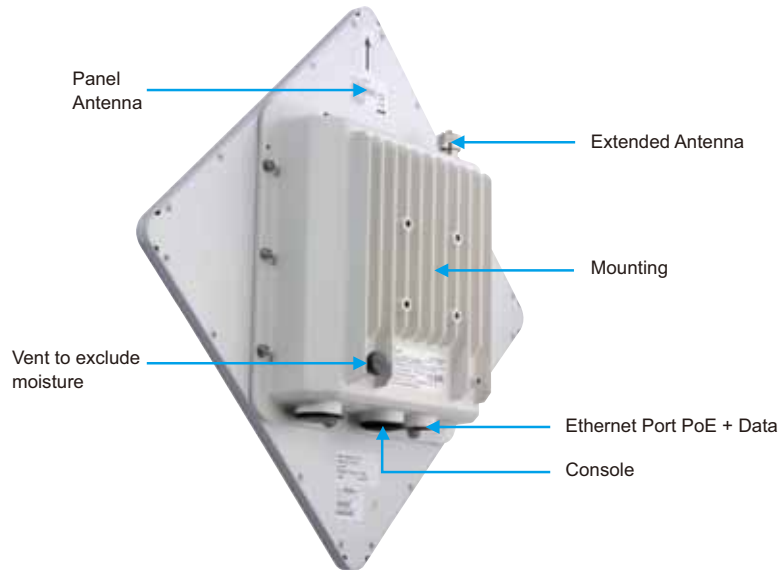

Dimensions (Unit = mm)

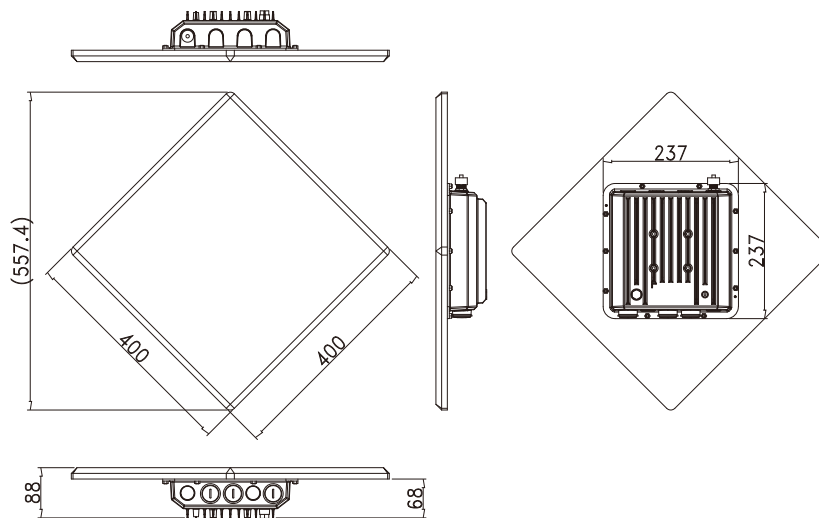

Specification

Technology

Standard:

IEEE 802.11a/b/g for Wireless LAN
 IEEE 802.11i Wireless Security
 IEEE 802.3u for 10/100Base-TX
 IEEE 802.3af for Power over Ethernet
 IEEE802.1D Spanning Tree Protocol

Performance

CPU: IXP425, 533MHz

System Memory:

16MB Flash
 32MB SDRAM

Operating Frequency:

5.8GHz Band:

FCC* : 5.725~5.850 GHz
 CE** : 5.470~5.600 GHz; 5.650~5.725 GHz

2.4GHz Band:

FCC : 2.412~2.462GHz
 CE : 2.412~2.472GHz
 (Programmable for different country regulations)

RF Modulation:

802.11a: OFDM (BPSK, QPSK, 16-QAM, 64QAM)
 802.11b/g: DSS (CCK, DQPSK, DBPSK)

RF Output Power (Max. of Avg.):

5.8GHz Band:

24dBm at Radio for FCC (Band 4)
 30dB EIRP for ETSI 301 893 (Band3)

2.4GHz Band:

23dBm (Max. of Avg.) at Radio for FCC
 20dB EIRP for CE (ETSI 300 328)
 (Controllable for different country regulations)

Sensitivity:

5.8GHz Band:

≤-90dBm @6Mbps
 ≤-73dBm @54Mbps

2.4GHz Band:

≤-96dBm @1Mbps
 ≤-90dBm @6Mbps
 ≤-72dBm @54Mbps

Default Antenna Characteristics

Gain: 23dBi

Frequency: 5400~5850 MHz

Direction: Directional Antenna

HPBW (Horizontal): 10 Deg.

HPBW (Vertical): 10 Deg.

Interface

Ethernet Port: 1 x 10/100Base-T, Auto Negotiation

RS-232: RS-232 (UART) in RJ45 Form Factor For debug purpose

P1: TXD0, P2: DSR0, P3: RXD0, P4: TXD1,

P5: RXD1, P6: DTR1, P7:Hard Reset, P8:GND

Buzzer: Embedded buzzer for power on and Antenna Alignment indication

Reset Pin:

Short P7 and P8 less than 1 sec. to reset system

Short P7 and P8 less than 5 sec. to reset to factory default

Cables: 2/4-pair UTP/STP Cat. 5 cable (100m)

Management

Management: Web UI (Secure SSL), Command Line Interface (SSH or RS-232 (9600)), Windows-based Utility, SNMPv2, DHCP Client, Configuration backup/restore,

Statistics: Wireless and Ethernet Traffic statistics

Firmware upgrade: Web, Windows management tool, TFTP, firmware backup

Operating Mode:

JetWave 2610/2640: Base Station, CPE, Point to Point, Point to Multiple Point

JetWave 2620: Base Station, CPE, Relay, Point to Point, Point to Multiple Point

Radio Bandwidth Control: 5MHz/10MHz/20MHz/40MHz

Super A/G: Fast Frames, Burst, Compression modes

TDM Coordination: Traffic management

Intel TDMA: For long distance transmission

Transmit Power Control: Adjust RF output power

Link Aggregation: To enhance Throughput with dual radio card (2620 only)

Distance in Meters: Auto ACK-Time adjustment

Wireless Isolation: Isolate Wireless data from clients

Antenna Alignment: Easy tool to align antenna performance

Link Test: Self-Wireless Connection test

Secured Access: HTTPS, SSH, 802.1x, Radius Server, Access Control by Trusted Wireless station, manually add station, MAC Address Authentication

Security Encryption: WEP 64/128/152 bits, WPA-PSK (TKIP), WPA2-PSK(AES), Mixed WPA/WPA2

STP: Spanning Tree Protocol with Fast Forwarding

NTP: Network Time Management

System Log: Log occurred events

Power Requirements

Power: Power over Ethernet, IEEE802.3af compliant

PoE Injector:

Input: 100-240VAC, 0.6A 50-60Hz

Output: 48V, 0.4A

Power Consumption: Above 6 Watts @ DC 48V, depend on user volume

Mechanical

Enclosure: IP-67 & Level 17 Beaufort Scale protection

Vent: Vent for exclude moisture

External Antenna connector: N-Type

Dimension:

Box: 237 mm (H) x 237 mm (W) x 68 mm (D)

Antenna: 320 mm (H) x 320 mm (W) x 18 mm (D)

Installation: Pole Mount (ADC-12 Aluminum alloy)

Weight: 4.43 kg with package

Environmental

Operating Temperature: -30 ~70°C

Operating Humidity: 10% ~ 95% (operating)

Storage Temperature: -40 ~ 85°C

Regulatory Approvals

EMI: FCC part 15 Subpart B&C, CE EN301 893(5G)

EMS: CE EN301 489-1/17

Shock: IEC60068-2-29

Vibration: IEC60068-2-6

Free Fall: IEC60068-2-32

Warranty: 3 years

Industrial
Intelligent
NMS

Rackmount
PoE Plus
Switch

Industrial
PoE Plus
Switch

Industrial
12-24V
PoE Switch

Industrial
PoE Switch

Rackmount
L3/L2 Switch

Gigabit
Managed
Switch

Managed
Ethernet
Switch

Entry-level
Switch

Wireless Outdoor AP

Embedded
PoE/Router
Computer
(LINUX)

Industrial
Communication
Computer
(WIN/LINUX)

Ethernet/PoE/
Serial Board

Ethernet
I/O Server

Media
Converter

Serial Device
Server

SFP Module

Din Rail
Power Supply



Ordering Information

JetWave 2610-EU Outdoor Long Range IEEE 802.11a Wireless AP, CE Frequency

JetWave 2620-EU Outdoor Long Range Dual IEEE 802.11a Wireless AP, CE Frequency

JetWave 2640-EU Outdoor Long Range Dual Band IEEE 802.11a + 802.11b/g Wireless AP, CE Frequency

JetWave 2610-US Outdoor Long Range IEEE 802.11a Wireless AP, FCC Frequency

JetWave 2620-US Outdoor Long Range Dual IEEE 802.11a Wireless AP, FCC Frequency

JetWave 2640-US Outdoor Long Range Dual Band IEEE 802.11a + 802.11b/g Wireless AP, FCC Frequency

Includes:

- JetWave Unit with integrated 23 dBi antenna
- Mounting Kit
- PoE Injector & Power cord
- Grounding Wire with Screw
- Waterproof RJ-45 Connector Kit
- Quick Installation Guide
- Document CD

Notice: Choose the available Radio Frequency for your country

Optional Antenna

Model Name	Description	Apply to	Apply to
JWA-5.8G-23dBi	Directional Panel Antenna 23dBi	JetWave 2620	Antenna Unit, Mounting Kit, 1m RF Cable, V-shape steel plank
JWA-5.8G-15dBi	Directional Panel Antenna 15dBi	JetWave 2620	Antenna Unit, Mounting Kit, 1m RF Cable
JWA-2.4G-15dBi	Omni-Directional Antenna 15dBi	JetWave 2640	Antenna Unit, Mounting Kit, 1m RF Cable
JWA-2.4G-12dBi	Sector-Directional Antenna 12dBi	JetWave 2640	Antenna Unit, Mounting Kit, 1m RF Cable
JWA-2.4G-9dBi	Omni-Directional Antenna 9dBi	JetWave 2640	Antenna Unit, Mounting Kit, 1m RF Cable
JWA-2.4G-5dBi	Omni-Directional Antenna 5dBi	JetWave 2640	Antenna Unit, Mounting Kit
JWA-Arrestor-5803	0-5G Arrestor for N-Type Antenna	All	

Power Source Device (PSE)

JetNet 4706 Industrial 6-Port Managed High Power PoE Switch

JetNet 4706f Industrial 6-Port Managed High Power PoE Fiber Switch

JetNet 4706f-w Industrial 6-Port Managed High Power PoE Fiber Switch w/ wide temp

JetNet 3706-RJ Industrial 6-port RJ45/IP67 PoE Switch

JetNet 3705 Industrial 5-port Power Over Ethernet Switch

JetNet 3705f Industrial 5-port Power Over Ethernet Fiber Switch

Note: Users would raise the power consumption to maximum.

To provide enough power, the High Power PoE Switch is recommended.

JetWave 2450

Outdoor High Performance IEEE 802.11b/g/n Wireless AP



CE FCC RoHS

- 802.11 b/g/n
- 3x↑ Rate
- WMM
- Built-in 8dBi Ant
- External N-type Ant.
- IGMP Snooping

- IEEE 802.11n wireless outdoor solution, backward compatible with 802.11b/g
- 3 times higher throughput than 802.11b/g solution, up to 150Mbps net data rate
- High performance and low maintaining cost for video surveillance network
- One model with both Embedded 8dBi Directional Antenna and N-Type Socket
- Up to 5KM Wireless coverage
- Wireless QoS (WMM) for video precedence transmission
- Supports Base Station, CPE, Point to Point and Point to Multiple Point connectivity
- Supports Spanning Tree Protocol, IGMP Snooping, SNMPv3, NTP, DHCP Server, Router mode
- Advanced security system by WEP, WPA, WPA2 and MAC address filter
- Built-in 12VDC PoE, to be powered through Ethernet cable
- -20~70°C operating temperature

- Industrial Intelligent NMS
- Rackmount PoE Plus Switch
- Industrial PoE Plus Switch
- Industrial 12-24V PoE Switch
- Industrial PoE Switch
- Rackmount L3/L2 Switch
- Gigabit Managed Switch
- Managed Ethernet Switch
- Entry-level Switch
- Wireless Outdoor AP**
- Embedded PoE/Router Computer (LINUX)
- Industrial Communication Computer (WIN/LINUX)
- Ethernet/PoE/ Serial Board
- Ethernet I/O Server
- Media Converter
- Serial Device Server
- SFP Module
- Din Rail Power Supply

Overview

The JetWave 2450 is a 2.4GHz IEEE 802.11n Wireless Outdoor Access Point compliant with the 802.11n standard and backward compatible with 802.11b/g standard. The 802.11n standard features 3 times better data rate than 802.11b/g standard, targeting to reach 60~80Mbps outstanding performance. The cost-effective JetWave 2450 with high throughput is the best wireless outdoor solution, especially for the video surveillance application.

JetWave 2450 integrates one 8dBi flat panel directional antenna and additional N-Type socket for optional antenna. With one model, you can freely use the embedded antenna for long distance line-of-sight transmission or attach high gain and wide directional antenna to extend the coverage in length and width depending on environmental needs. You can also save the storage, choose optional antenna only when embedded one is not suitable for use.

The JetWave 2450 delivers high output power and high receiver sensitivity, which can extend range and provide from 1 to 5KM wireless coverage. The high throughput 802.11n wireless transmission reduces the roaming between APs and provides stable wireless connection. The IP55 waterproof standard, -20~70°C operating temperature allows users to install the device under harsh environmental conditions. The 12VDC power input can be delivered through the Ethernet cable by the attached injector.

The advanced features include Spanning Tree Protocol to avoid the loop storm, QoS (WMM) to prioritize classes for different applications, IGMP snooping for multicast stream filtering, secure system by WEP, WPA, WPA2 and MAC address filtering and SNMPv3 management. Combining superior wireless technology and advanced features, the JetWave 2450 Wireless Outdoor Access Point is a reliable, high-performance solution for the most demanding wireless networking environments.

Specification

Technology

Standard:

IEEE 802.11b/g and 802.11n draft for Wireless LAN
 IEEE 802.11i Wireless Security
 IEEE 802.3u for 10/100Base-TX
 IEEE802.1D Spanning Tree Protocol

Performance

CPU: Atheros AR7240

System Memory: 8MB Flash, 32MB DDR

Operating Frequency:

IEEE 802.11b/gn HT20 ISM Band
 *FCC: 2.412 GHz ~ 2.462 GHz (CH1 ~ CH11)
 *ETSI: 2.412 GHz ~ 2.472 GHz (CH1 ~ CH13)
 IEEE 802.11g/n HT40 ISM Band
 *FCC: 2.422GHz ~ 2.452 GHz (CH3 ~ CH9)
 *ETSI: 2.422 GHz ~ 2.462 GHz (CH3 ~ CH11)

RF Modulation:

Transmission/Emission Type: Direct Sequence Spread Spectrum (DSSS)
 Data modulation type: OFDM/BPSK/QPSK/CCK/DQPSK/DBPSK

RF Output Power:

FCC: (Average Output Power @ 25°C)
 802.11b: 26 ± 1.5dBm
 802.11g: 6-24Mbps: 26 ± 1.5dBm,
 36-48Mbps: 25 ± 1.5dBm, 54Mbps: 24 ± 1.5dBm
 802.11n:
 HT20: 22/23/24/25/26 ± 1.5dBm (MCS7/6/5/4/0-3)
 HT40: 21/22/23/25/26 ± 1.5dBm (MCS7/6/5/4/0-3)
 PS: FCC band edge exclusive

ETSI(CE):

802.11b: Max. 10.5dBm
 802.11g: Max. 10.5dBm
 802.11n:
 Max. 10.5dBm@HT20
 Max. 10.5dBm@HT40

Sensitivity:

IEEE 802.11b: 1Mbps ≤ -93dBm, 11Mbps ≤ -88dBm
 IEEE 802.11g: 6Mbps ≤ -88dBm, 54Mbps ≤ -73dBm
 IEEE 802.11n
 *HT 20 MCS0 ≤ -88dBm, MCS7 ≤ -70dBm
 *HT 40 MCS0 ≤ -84dBm, MCS7 ≤ -67dBm

Data Rate:

11b: 11M, 5.5M, 2M, 1Mbps
 11g: 54M, 48M, 36M, 24M, 18M, 12M, 9M, 6Mbps
 11n draft:
 6M, 6.5M, 13M, 13.5M, 19.5M, 26M, 27M, 39M, 40.5M,
 53M, 54M, 58.5M, 65M, 78M, 81M, 104M, 108M, 117M,
 121.5M, 130M, 135Mbps

Default Antenna Characteristics

Gain: 8dBi

Direction: Directional Antenna

HPBW (Horizontal): 10 Deg.

HPBW (Vertical): 10 Deg.

Reserve N-Type Connector, switchable by SW

Interface

Ethernet Port: 1 x 10/100Base-T, Auto Negotiation

Reset: One Reset button to restore factory default

Cables: 2/4-pair UTP/STP Cat. 5 cable (50m)

Management

Management: Web UI, SNMP, DHCP Client, Configuration backup/restore, JetView Protocol

Statistics: Wireless and Ethernet Traffic statistics

Firmware upgrade: Web, Windows management tool, TFTP, firmware backup

Operating Mode: Base Station, CPE, Peer to Peer, Peer to Multiple Peer

AP Mode: SSID configurable, Hide SSID, Channel Selection, Limitation of Client connection, Wireless client isolation, Tx Flow Control

CPE Mode: SSID configurable, CPU with multi-client support, TX Flow Control by AP

Output Power Control: Full, 50%, 25%, 12.5%, Min

Data Rate Selection: Best or adjust target data rate

Site Survey: Easy tool to discover available AP

Link Test: Self-Wireless Connection test

Secured Access: 802.1x, Radius Server, Access Control by Trusted Wireless station, manually add station, HTTPS(*), SSH(*)

Security Encryption: WEP 64/128/152 bits, WPA-PSK (TKIP), WPA2-PSK(AES), Mixed WPA/WPA2

STP: Spanning Tree Protocol with Fast Forwarding

NTP: Network Time Management

IGMP Snooping: Filter the multicast stream

System Log: Log occurred events

Port Mode: Bridge or router mode

DHCP Server: Assign IP address to connected clients

LED:

Power: Green ON/OFF, Amber Blinking – Device initial
 LAN: Green ON/OFF, Blinking – Sending/Receiving data
 WLAN (AP mode):
 Green Off – WLAN Disabled,
 Green Blinking – WLAN Activity
 WLAN (CPE mode):
 Green Blinking – Good Quality
 Yellow Blinking – Marginally Acceptable Quality
 Red Blinking – Bad Quality

Power Requirements

Power: Power over Ethernet Cable, Up to 50 meter

Power Injector:

Input: 100-240VAC, 0.6A 50-60Hz
 Output: 12V, 1A

Power Consumption: Max. 12V, 900mA, depend on user volume

Mechanical

Enclosure: IP55 Plastic

External Antenna connector: Reverse N-Type

Dimension: 165mm (H) x 60 mm (W) x 34 mm (D)

Installation: Pole Mount (ADC-12 Aluminum alloy)

Weight: 1 kg with package

Environmental

Operating Temperature: -20 ~70°C
Operating Humidity: 10% ~ 95% (operating)
Storage Temperature: -30 ~ 80°C

Regulatory Approvals

EMI: FCC part 15 Subpart B&C, CE EN300 328
EMS: CE EN301 489-1/17
Warranty: 3 years

Ordering Information

JetWave 2450-FCC Outdoor High Performance IEEE 802.11b/g/n Wireless AP, FCC Adapter

JetWave 2450-EU Outdoor High Performance IEEE 802.11b/g/n Wireless AP, CE Adapter

Includes:

- JetWave Unit
- Mounting Kit
- PoE Injector & Power cord
- Grounding Wire with Screw
- Quick Installation Guide
- Document CD

Notice: The CE or FCC Frequency is changeable by UI.

Optional Antenna

Model Name	Description	Apply to
JWA-2.4G-15dBi	Omni-Directional Antenna 15dBi	Antenna Unit, Mounting Kit, 1m RF Cable
JWA-2.4G-9dBi	Omni-Directional Antenna 8dBi	Antenna Unit, Mounting Kit, 1m RF Cable
JWA-2.4G-5dBi	Omni-Directional Antenna 5dBi	Antenna Unit, Mounting Kit
JWA-2.4G-12dBi	Sector-Directional Antenna 12dBi	Antenna Unit, Mounting Kit, 1m RF Cable

Industrial
Intelligent
NMS

Rackmount
PoE Plus
Switch

Industrial
PoE Plus
Switch

Industrial
12-24V
PoE Switch

Industrial
PoE Switch

Rackmount
L3/L2 Switch

Gigabit
Managed
Switch

Managed
Ethernet
Switch

Entry-level
Switch

**Wireless
Outdoor AP**

Embedded
PoE/Router
Computer
(LINUX)

Industrial
Communication
Computer
(WIN/LINUX)

Ethernet/PoE/
Serial Board

Ethernet
I/O Server

Media
Converter

Serial Device
Server

SFP Module

Din Rail
Power Supply