



## JetCard Series Industrial Ethernet / PoE / Serial Boards

Korenix provides all kinds of industrial embedded boards for system integrators to extend their current systems or combine with other boards or add-on software to form whole new products.

### Single Board Computer

The JetCard 5400 is a RISC-based 3.5" single board computer, which carries one WAN and four LAN ports and is pre-installed with Embedded Linux and advanced layer-3 router and VPN functionality. One USB and one console ports are convenient for program development and control. For more flexibility, the JetCard 5400 has one PCI-104 bus which can extend up to four

PCI-104 cards with different functions such as serial, gigabit Ethernet, VGA, CANbus...etc. Therefore, the JetCard 5400 is an ideal development platform for industry to apply in all kinds of control applications. Furthermore, as the JetCard 5400 is the main board of the JetBox 9400 series, it is also a great development kit for early SW evaluation of the JetBox 9400 series.

### PCI-104 Add-on Card: GbE Switch, FE Switch, Serial

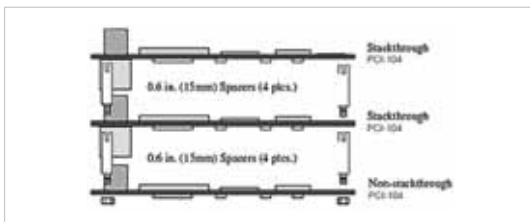

The PCI-104 form factor supports the PCI bus. The maximum configuration for the PCI bus of PC/104-Plus or PCI-104 modules is four, plus the Host Board. Korenix provides following PCI-104 Cards:

- JetCard 2154G GbE switch card**
- JetCard 2105 Fast Ethernet switch card**
- JetCard 1608 Serial card**

### UPCI Add-on Card: Booster PoE Switch, FE Switch, Serial

Korenix provides various Universal PCI form factor cards with Windows or Linux drivers. The easy-to-install drivers that come with JetCard make it easier for users to extend their system.

- JetCard 2215 Booster PoE switch card**
- JetCard 2205 Fast Ethernet switch card**
- JetCard 1204/1208/1208L RS232 card**
- JetCard 1402/1402i RS422/485 card**
- JetCard 1404/1404i RS422/485 card**

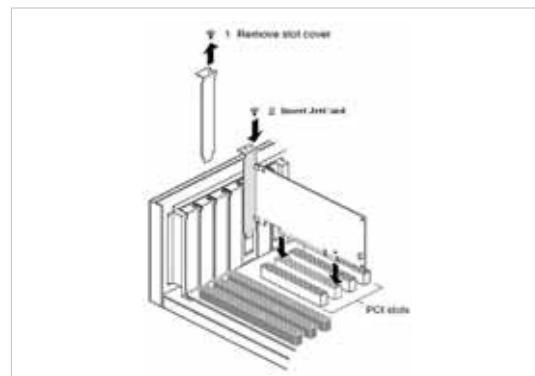

- All product specifications are subject to change without further notice.
- Before applying to critical projects, please contact Korenix headquarter for up-to-date product specifications' consultancy.

## NVR System Integration

### Enhanced Network Connectivity through Non-Stop Video Recording



Today there is a growing demand of deploying reliable and cost-effective IP video surveillance solutions in any public and / or private sector. In this context, the NVR systems become the industry standard for long term video archiving and storage. To fulfill the vertical market need of an optimized solution, the NVRs should be designed more intelligently and with reduced costs and maintenance time. The IP video recording provider designed an all-in-one

NVR system by replacing the original external router and switch with a Korenix JetCard 5400-w embedded single board computer. The exclusive design of the embedded Linux computer with internal switch control pin header allows it to be easily connected with the video recorder in a compact rackmount chassis. Using its integrated LAN ports, the JetCard 5400-w acts as an industrial Ethernet switch while connecting to multiple devices, such as cameras, sensors etc., and storing all the collected information in the Network Video Recorder. As a result, no need occurs of using additional switching device, which obviously reduces installation costs. The JetCard 5400-w brings even more flexibility to users, by allowing them to use the USB dongle for transferring wireless data to the desired control device.

Based on the windows system, the video recorder, which is in charge of video encoding & decoding, can integrate in it the JetCard 5400-w, a performance-optimized Linux-based system for IP video package transmission. The 2 operating systems can function perfectly without interfering one another's operation. This benefits users, allowing them to choose the OS they want to use for their specific applications.

The complete layer3 routing functionalities of JetCard 5400-w are later being used for providing efficient management of extended network groups. Furthermore, the VPN allows administrators to use it as a gateway for establishing long-distance and secured network connections over WAN while expanding their networking capabilities and reducing system costs.

With the supported -40~80°C wide operating temperature range, the embedded single board computers provide stable and efficient communication while enhancing network infrastructures and providing reliable video stream collection, recording and transmission in severe industrial environments.

#### Main Products

- JetCard 5400-w Embedded Linux 3.5" Single Board VPN Router Computer with PCI-104 slot

#### Why Korenix

- Internal switch control pin header ensures easy connection with NVR system
- Built-in Linux OS for IP video stream transmission
- 5 Ethernet ports provide multiple connectivity while reducing installation costs
- Layer 3 routing and VPN enhance the secure network infrastructure construction and management

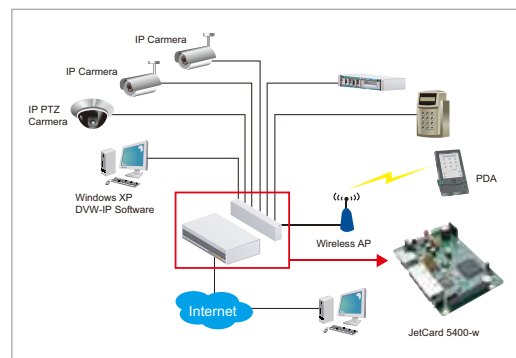

- Industrial Intelligent NMS
- Rackmount PoE Plus Switch
- Industrial PoE Plus Switch
- Industrial 12-24V PoE Switch
- Industrial PoE Switch
- Rackmount L3/L2 Switch
- Gigabit Managed Switch
- Managed Ethernet Switch
- Entry-level Switch
- Wireless Outdoor AP
- Embedded PoE/Router Computer (LINUX)
- Industrial Communication Computer (WIN/LINUX)
- Ethernet/PoE/ Serial Board**
- Ethernet I/O Server
- Media Converter
- Serial Device Server
- SFP Module
- Din Rail Power Supply

## Mobile DVR System

### Cost-Effective and Optimized Video Monitoring System



Transportation authorities and bus manufacturers are increasingly deploying mobile video solutions for reliable, onboard surveillance and incident recording. The emerging technological innovations and the revolution of IP video surveillance are combining to provide users with smarter and more efficient network video monitoring solutions. However, providing a complete IP surveillance networking solution in vehicles can be troublesome and expensive with a number of devices used separately to deliver power to IP cameras, collect and manage video streams, etc. Moreover, the power sourcing equipment in transit systems are incapable

to provide 48V power which is required for standard IP cameras in transit systems.

JetCard 2215 appeared to be an ideal embedded solution for the Transit System Integrating Company to overcome all these difficulties and provide optimized network video monitoring with reduced costs.

Designed with a Universal PCI slot, the 5 RJ45 port PoE switch card can be easily installed in a DVR system. The integrated DVR system with 12~24V power input enables the PoE function of the JetCard 2215, which, using the exclusive power booster technology, converts it to 48V power to deliver 15.4W per port to the IP cameras inside the vehicle. In the meantime, using its 4 PoE ports, the PoE card collects the data from the IP cameras into the embedded video system. As a result, the device functions as an Ethernet switch and powering switch, while reducing the number of necessary devices and maintenance costs of the total IP surveillance networking solution.

In addition, to ensure the reliable data transmission with zero packet loss under temporary traffic congestion, JetCard supports back pressure and pause frame-based flow control scheme. Equipped with easy-to-install drivers, the 12-24V booster PoE switch card can be smartly integrated in a DVR system to work as a complete video recording system. Therefore, it is also suitable to apply in many other industrial applications, such as banking, city surveillance...etc.

Implementing the JetCard 2215, administrators are able to enhance their on-board surveillance by a centralized remote surveillance, meanwhile reducing the system control and related costs.

#### Main Products

- JetCard 2215 Embedded Booster PoE UPCI Switch Card

#### Why Korenix

- 32bits Universal PCI bus for adding in DVR
- 12~24VDC to 48V PoE Booster for powering IP cameras in bus
- 4 PoE ports for reducing wiring and installation costs

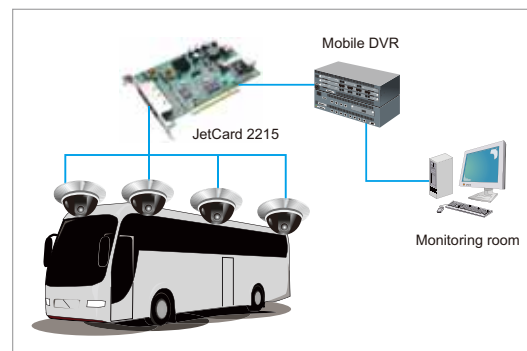

# Entertainment System

## High Performance and Reliable Network by High-Bandwidth Connectivity



The modern consumer's increasing need for entertainment and video data while on the move forces the transit system integrators to offer intelligent multi-zone information in order to generate their extensive competitiveness in the market. This leads to the development and growth of the rear-seat entertainment systems market. To provide a solution like this, IPC devices with high-bandwidth data transmission capability are required, that can transfer a large number of video and audio information.

Korenix JetCard 2154G embedded gigabit PCI-104 switch card has been integrated in an IPC system to ensure real-time high bandwidth data transmission with reduced system costs.

Using the easy-to-install drivers, the device can be easily set up in the IPC system. Through its 4 gigabit ports, the switch card is capable of connecting multiple monitor devices at the same time, in order to show different entertainment information, such as displaying videos, running different games, providing a status route map, etc.

To ensure the high quality network performance, the JetCard 2154G supports QoS, which allows prioritizing traffic transmission to IPC. Besides, the JetCard 2154G also supports back pressure and pause frame-based flow control schemes, which will ensure zero packet loss under temporary traffic congestion.

Combining the -25~70°C operating temperature and overload current/voltage protection, JetCard 2154G becomes a highly reliable and cost-effective embedded networking solution for deploying in modern airplanes, buses, trains and other transit systems.

### Main Products

- JetCard 2154G Embedded Gigabit PCI-104 Switch Card

### Why Korenix

- Easy-to-install 32bits PCI-104 Card for system integration
- 4 Gigabit ports for high-bandwidth data transmission
- QoS and flow-control for high-performance data transmission
- -25~70°C operating temperature for applications with wide temperature variations



- Industrial Intelligent NMS
- Rackmount PoE Plus Switch
- Industrial PoE Plus Switch
- Industrial 12-24V PoE Switch
- Industrial PoE Switch
- Rackmount L3/L2 Switch
- Gigabit Managed Switch
- Managed Ethernet Switch
- Entry-level Switch
- Wireless Outdoor AP
- Embedded PoE/Router Computer (LINUX)
- Industrial Communication Computer (WIN/LINUX)
- Ethernet/PoE/Serial Board**
- Ethernet I/O Server
- Media Converter
- Serial Device Server
- SFP Module
- Din Rail Power Supply

## Korenix Product Selection Guide – Industrial Ethernet / PoE / Serial Boards



JetCard 5400  
3.5" SBC w/  
PCI-104 bus



JetCard 2154G



JetCard 2105



JetCard 1608



JetCard 2215



JetCard 2205

3.5" SBC w/ PCI-104 bus	PCI-104 Switch Card	PCI-104 Switch Card	PCI-104 Serial Card	UPCI Switch Card	UPCI Switch Card
----------------------------	---------------------	---------------------	---------------------	------------------	------------------

Function	Linux-Ready Single Board Computer	Gigabit Ethernet Switch Card	Ethernet Switch Card	Serial Card	PoE Ethernet Switch Card	Ethernet Switch Card
Ports	10/100Mbps Ethernet x 5 USB2.0 x1/Console x1 reset x1	10/100/1000Mbps Ethernet x 4	10/100Mbps Ethernet x 5	RS-232/422/485 x 4 external RS-232 x 4 internal	10/100Mbps Ethernet x 5 (4 ports with PoE, 15.4W)	10/100Mbps Ethernet x 5
Max. Stacked Boards	4	4	4	4	4	4
Bus interface	32-bit PCI-104	32-bit PCI-104	32-bit PCI-104	32-bit PCI-104	32-bit UPCI	32-bit UPCI
Power Input	DC 12~48V terminal block (Power consumption Max. 25W)	PCI-104 bus	PCI-104 bus	PCI-104 bus	DC 12~24V external power input (ATX 4Pin Connector)	UPCI bus
Board Connector	RJ45 x 5 external	RJ45 x 4 external	RJ45 x 4 external RJ45 x 1 internal	DB-37 female x 1 external Box header x 1 internal	RJ45 x 4 external RJ45 x 1 internal	RJ45 x 4 external RJ45 x 1 internal
Cable Connection		RJ45	RJ45	DB-9/DB-25	RJ45	RJ45
Communication Controller	CPU: Intel IXP435 400MHz RISC 128MB DDR2 RAM	Marvell 88E8001 Marvell 88E6161	Realtek 8139C+ Marvell 88E6065	Oxford OXmPCI954	Realtek 8139C+ Marvell 88E6065	Realtek 8139C+ Marvell 88E6065
Performance	L3 routing VPN, IPv6 Managed switch	10/100/1000Mbps with auto MDI/MDI-x, Ethernet Statistics monitor	10/100Mbps with auto MDI/MDI-x, Ethernet Statistics monitor	FIFO 128 Bytes, Up to 921.6Kbps, SW Flow Control	10/100Mbps with auto MDI/MDI-x, Ethernet Statistics monitor	10/100Mbps with auto MDI/MDI-x, Ethernet Statistics monitor
Operating Temperature	-40~80°C	-25~70°C	-25~70°C	-25~70°C	-25~70°C	-25~70°C

Operating System						
Windows		7/NT/2000/2003/XP	Vista/NT/2000/2003/XP	Vista/2000/2003/XP	Vista/NT/2000/2003/XP	Vista/NT/2000/2003/XP
Linux Kernel	Embedded Linux 2.6.20	2.4x/2.6x	2.4x/2.6x		2.4x/2.6x	2.4x/2.6x



JetCard 1208L



JetCard 1204/ 1204-w



JetCard 1208 / 1208-w



JetCard 1402 / 1402i



JetCard 1404 / 1404i

Multi-Port Serial Card	Multi-Port Serial Card	Multi-Port Serial Card
------------------------	------------------------	------------------------

Function	UPCI (Low profile)	UPCI	UPCI	UPCI	UPCI
Ports	RS-232 x 8	RS-232 x 4	RS-232 x 8	RS-422/485 x 2	RS-422/485 x 4
Max. Stacked Boards	4	4	4	4	4
Bus interface	32-bit Universal PCI	32-bit Universal PCI	32-bit Universal PCI	32-bit Universal PCI	32-bit Universal PCI
Board Connector	VHDCI68	DB-37 female	DB-62 female	DB-9 male x2	DB-37 female
Cable Connection	DB-9/DB-25	DB-9/DB-25	DB-9/DB-25	DB-9/DB-25	DB-9/DB-25
Communication Controller	16C950 Compatible	16C950 Compatible	16C950 Compatible	16C950 Compatible	16C950 Compatible
Performance	FIFO 128 Bytes, Up to 921.6Kbps, 15KV ESD protection, HW/SW Flow Control	FIFO 128 Bytes, Up to 921.6Kbps, 15KV ESD protection, HW/SW Flow Control	FIFO 128 Bytes, Up to 921.6Kbps, 15KV ESD protection, HW/SW Flow Control	FIFO 128 Bytes, Up to 921.6Kbps, 15KV ESD protection, HW/SW Flow Control	FIFO 128 Bytes, Up to 921.6Kbps, 15KV ESD protection, HW/SW Flow Control
Optical Isolation Protection: 2KV per Port				JetCard 1402i	JetCard 1404i
Operating Temperature	-10~70°C	-10~70°C (JetCard 1204 / 1208) -40~80°C (JetCard 1204-w/1208-w)		-10~70°C	-10~70°C

Operating System					
Windows	7/Vista/Me/2000/XP	7/98/Me/NT/2000/XP/2003	7/98/Me/NT/2000/XP/2003		
Linux Kernel	2.4x/2.6x	2.4x/2.6x		2.4x/2.6x	

## JetCard 5400-w

### Linux-Ready PCI-104 Single Board Computer



CE FC  RoHS

Linux SDK PCI-104 12~48VDC

USB -40~80°C

- Intel IXP435 400MHz networking processor to enhance routing and VPN performance
- 5 Ethernet ports: 1 WAN, 4 LAN
- 1 USB, 1 console port, 1 reset button
- VPN for enhanced secure networkin
- 12~48V DC input
- Embedded Linux ready
- Router/ Ethernet switch function support
- Linux SDK for customized applications
- -40~80°C operating temperature for hazardous environment application



- Industrial Intelligent NMS
- Rackmount PoE Plus Switch
- Industrial PoE Plus Switch
- Industrial 12-24V PoE Switch
- Industrial PoE Switch
- Rackmount L3/L2 Switch
- Gigabit Managed Switch
- Managed Ethernet Switch
- Entry-level Switch
- Wireless Outdoor AP
- Embedded PoE/Router Computer (LINUX)
- Industrial Communication Computer (WIN/LINUX)
- Ethernet/PoE/ Serial Board**
- Ethernet I/O Server
- Media Converter
- Serial Device Server
- SFP Module
- Din Rail Power Supply

## Overview

The JetCard 5400-w is a RISC-based 3.5" single board computer with Embedded Linux ready and advanced layer-3 router functionality. For more flexibility, the JetCard 5400-w has one PCI-104 bus which can extend up to 4 PCI-104 cards with different functions such as serial, gigabit Ethernet, VGA, or CANbus...etc. Therefore, the JetCard 5400-w is an ideal development platform for industry to apply in all kinds of control applications.

### PCI-104 stacking

The PCI-104 form factor supports the PCI bus. The maximum configuration for the PCI bus of PC/104-Plus modules is four plus the Host Board.

Figure 1: A Possible Module Stack Configuratuin

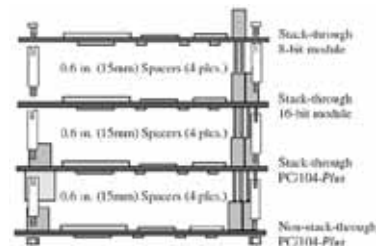

## Dimensions (Unit = mm)

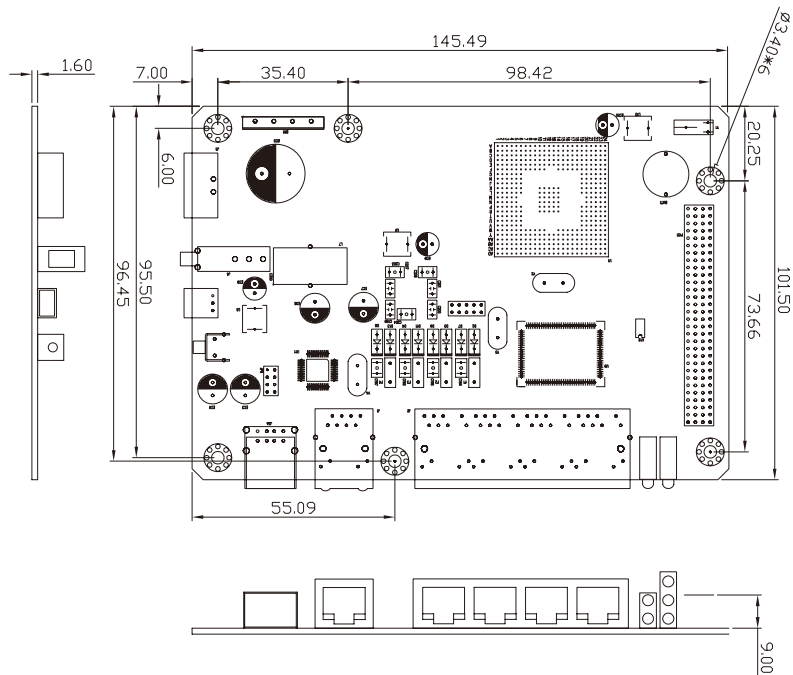

## Specifications

### System

**Processor:** Intel Xscale IXP435 400MHz\*, fanless

**System memory:** 128MB DDR2 RAM

**System flash:** 32MB

**Ethernet:** 10/100 Based-Tx RJ-45 connector x5

**USB:** USB 2.0 x1 (Host)

**Supporting devices:** USB flash, wireless dongle

**Console port:** 3-pin header (RS232 interface)

**LED per Ethernet port:**

Link/Activity (Green on/Green blinking)

Full Duplex/Collision (Yellow on/ Yellow blinking)

**LED per unit:**

Power on/off x1 (Green on/off)

**Reset button x1**

**HW Watchdog timer:**

Generates a time-out system reset, 1sec

**Power on/off switch x1**

**Power Supply:**

DC 12~48V

**Power Consumption:** Max. 25W

**OS support:** Embedded Linux 2.6.20

### Mechanical

**Dimension:** 146 (W) x 102 (D) mm

**Net weight:** 0.4kg

### Environment

**Operating Temp:**

-40 ~ 176°F(-40 ~ 80°C), 5 to 95% RH

**Storage Temp:** -40 ~ 176°F(-40 ~ 80°C), 5 to 95% RH

### Regulation

FCC class A, CE

EN55022 class A

EN55024

EN61000-3-2, 3

EN61000-4-2, 3, 4, 5, 6, 8, 11

**MTBF:** Greater than 200,000 hours @25°C

**Warranty:** 5 years

\*Specifications may change without prior notice

## Linux Specifications

### Embedded Linux

**Bootloader:** JetBox bootloader

**Linux Kernel:** 2.6.20

**Shell:** GNU ash

**File system:** jffs2, NFS, Ext2, Ext3, VFAT, FAT

**Device drivers:** USB, Watchdog timer, UART, Ethernet, DIO, PoE, SD/mSD card, CF card, HW IPsec VPN, HW Open VPN, JetCard1608/ 2105/ 2154G, VGA\*, Mobile dongle\*, GPS dongle\*

**Protocols:** ARP, PPP, CHAP, IPv4, IPv6, PAP, ICMP, TCP, UDP, NFS, SNMP v1/v2c/v3, NTP, SSH1.0/2.0, SSL, OpenVPN, Ipsec, PPP, PPPoE, PPTP, FTP, HTTP, SMTP, DNS, L2TP, DVMRP, OSFP, RIP v1.0/2.0, BGP\*, ISIS\*, VRRP\*, 802.11\*, HSDPA\*, GPRS\* telnet, dhcp, VLAN

**SW package:** Busybox (telnetd, inetd, udhcp, syslogd), e2fsprogs, firmware, i2c-tools, microcom, mtd, netcat, pciutils, ser2net, setserial, ssdutil, usbmount, usbutils, version, bridge-utils, ethtool, iptables, net-snmp, ntp, openssh, openssl, openvpn, openswan, pppd, rp-pppoe, pptp-linux, proftpd, samba, goahead, mutt, bind, l2tp, mroute, quagga, vrrpd, wireless-tools, wvdial

### Korenix Linux auto-run function

Customized configuration

Process monitoring

### SDK

**Linux tool chain:** Gcc(C/C++ PC cross compiler), uClibc

### Linux sample code

Note: Software supports differ from HW functions of each model

## Ordering Information

### JetCard 5400-w Linux-Ready PCI-104 Single Board Computer

Includes:

- JetCard 5400-w x1
- Console cable x1
- Attached 2-pin power terminal block
- Quick installation guide
- Documentation and software CD-ROM

- Industrial Intelligent NMS
- Rackmount PoE Plus Switch
- Industrial PoE Plus Switch
- Industrial 12-24V PoE Switch
- Industrial PoE Switch
- Rackmount L3/L2 Switch
- Gigabit Managed Switch
- Managed Ethernet Switch
- Entry-level Switch
- Wireless Outdoor AP
- Embedded PoE/Router Computer (LINUX)
- Industrial Communication Computer (WIN/LINUX)
- Ethernet/PoE/Serial Board**
- Ethernet I/O Server
- Media Converter
- Serial Device Server
- SFP Module
- Din Rail Power Supply

## JetCard 2154G

### 4-port Gigabit Ethernet Switch PCI-104 Card



CE FC  RoHS



- Supports 32 bit PCI-104 bus
- 4 10/100/1000TX ports with Auto MDI/MDI-X
- IEEE 802.3 10Base-T/100Base-Tx/ 1000Base-T compatible
- Full or half duplex at 10/100/1000 Mbps
- IEEE 802.3u Auto-Negotiation supported
- Up to 10K Jumbo Frame supported for secure large file transmission
- QoS supported for packet forwarding precedence
- Supports Windows 7/NT/2000/2003/XP, Linux 2.4/2.6
- -25~70°C operating temperature for hazardous environment application



## Embedded Switch Card

The JetCard 2154G is a flexible and high performance four-port Ethernet switch card in PCI-104 format. The PCI-104 bus of JetCard 2154G supports both +3.3V and +5V slot. The easy-to-install drivers that come with JetCard make it easier for you to set up your complex system. With its -25~70°C wide operating temperature range, JetCard 2154G becomes an ideal embedded networking solution for industrial applications in severe environments.

The JetCard 2154G uses Marvell 88E6161 chip to provide 4 Gigabit Ethernet ports. Each Ethernet port in the JetCard offers IEEE 802.3 compliant Ethernet data transmission with auto MDI/MDI-X and auto-negotiation, and 1000 Base-T with 10K Jumbo frames.

### Jumbo frames

Jumbo frames are Ethernet frames with more than 1,500 bytes of payload (MTU). The JetCard 2154G can support up to 10Kbyte of payload. Jumbo frames can help performance by reducing the load on the CPU (by requiring fewer headers to be processed for the same amount of payload data).

**Auto MDI/MDI-X:** The JetCard automatically determines whether or not it needs to interchange cable sense between pairs so that an external crossover cable is not required. If the JetCard interoperates with a device that cannot automatically correct for crossover, the JetCard makes the necessary adjustment prior to commencing Auto-Negotiation.

**Flow control:** The JetCard supports back pressure and pause frame-based flow control schemes to ensure zero packet loss under temporary traffic congestion.

**QoS (Quality of Service):** QoS for networks is an industry-wide set of standards and mechanisms for ensuring high-quality performance for critical applications. The JetCard provides the shared memory-based QoS switch architecture. Packets are directed into one of four traffic class queues based upon Port, IEEE 802.1p, IPv4's TOS or Diff-Serv, or IPv6's Traffic Class.

## PCI-104

The PCI-104 form factor supports the PCI bus. The maximum configuration for the PCI bus of PCI-104

modules is four plus the Host Board.

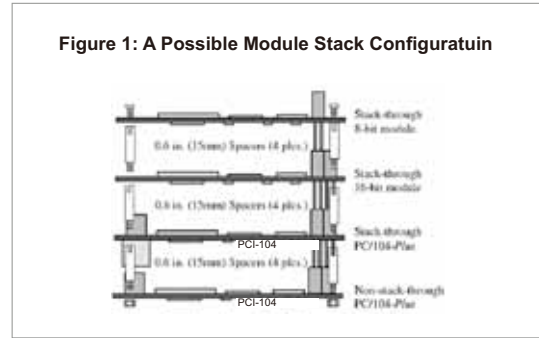
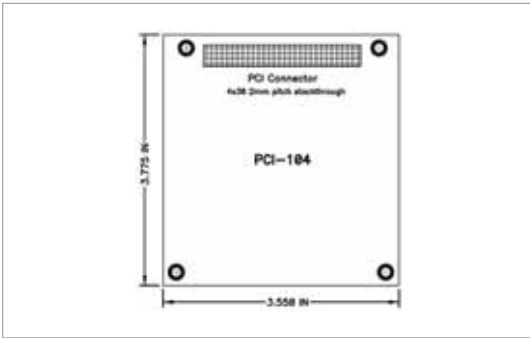

- Industrial Intelligent NMS
- Rackmount PoE Plus Switch
- Industrial PoE Plus Switch
- Industrial 12-24V PoE Switch
- Industrial PoE Switch
- Rackmount L3/L2 Switch
- Gigabit Managed Switch
- Managed Ethernet Switch
- Entry-level Switch
- Wireless Outdoor AP
- Embedded PoE/Router Computer (LINUX)
- Industrial Communication Computer (WIN/LINUX)
- Ethernet/PoE/ Serial Board**
- Ethernet I/O Server
- Media Converter
- Serial Device Server
- SFP Module
- Din Rail Power Supply

## Dimensions (Unit = mm)

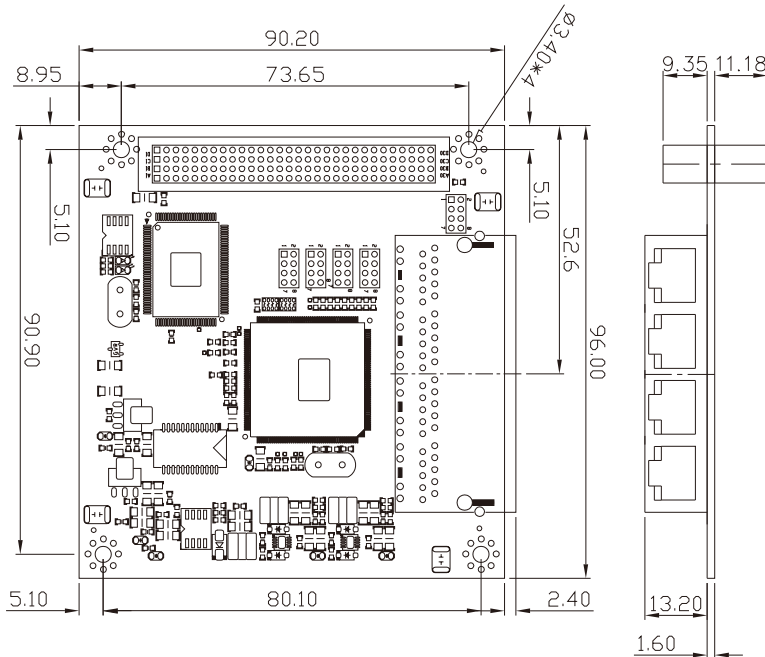

## Specifications

### Technology

#### Standard:

IEEE802.3 10 Base T  
IEEE802.3u 100 Base-Tx  
IEEE802.3ab 1000 Base-T  
IEEE802.1p Class of Service  
IEEE802.3x Flow Control and Back Pressure

**Processing:** Store and Forward architecture

**Packet filter:** Broadcast packet filtering

### Interface

**Bus interface:** 32-bit PCI-104 bus

**Number of ports:** 4 Ethernet ports

10/100/1000 Base-Tx with auto MDI/MDI-X Auto-negotiation

#### LED on Ethernet port:

Gigabit cooper: Link/ Activity (Green on/ blinking)

Gigabit cooper: Speed 1000M/ other (Yellow on/ off)

**IRQ:** assigned by Universal PCI plug and play

#### OS supported:

Windows 7/NT/2000/2003/XP

Linux 2.4.x/2.6.x

(Refer to "Marvell Yukon Chipset" driver of Linux kernel)

### Hardware

#### Communication controller:

Marvell 88E8001

Marvell 88E6161

**Board connector:** RJ45

#### Cable connection:

10 Base-T: 2-pair UTP/STP Cat. 3,4,5 cable (100m)

100 Base-Tx: 2-pair UTP/STP Cat. 5 cable (100m)

1000 Base-T: 4-pair UTP/STP Cat. 5 cable (100m)

**Dimension:** 96 x 90 mm

**Net weight:** 200g

### Performance

**Transfer performance:** 14,880pps for Ethernet and 148,800pps for Fast Ethernet, 1,488,000pps for Gigabit Ethernet

#### Transfer packet size:

Up to 10K bytes Jumbo frames for GbE port

64 to 1522bytes

**MAC address:** 1K MAC

**Memory buffer:** 1 Mbits

### Power requirement

**Power consumption:** 0.95A (+3.3V)

### Environment

#### Operating Temp:

-25 ~ 70°C (-13 ~ 158°F), 5 to 95% RH

**Storage Temp:** -40 ~ 80°C (-40 ~ 176°F), 5 ~ 95% RH

**Regulation:** CE, FCC

**Warranty:** 5 years

## Ordering Information

### JetCard 2154G 4-Port Gigabit Ethernet Switch PCI-104 Card

Includes:

- JetCard 2154G
- Quick installation guide
- Documentation and software CD-ROM
- Screw Pack

## JetCard 2105

### 5-port 10/100Mbps Fast Ethernet Switch PCI-104 Card



CE FC RoHS

PCI-104 QoS -25~70°C

- Supports 32 bit PCI-104 bus
- 5 10/100TX ports with Auto MDI/MDI-X
- IEEE 802.3 10 Base-T and 100 Base-Tx compatible
- Full or half duplex at 10/100 Mbps
- IEEE 802.3u Auto-Negotiation supported
- QoS supported for packet forwarding precedence
- Supports Windows Vista/NT/2000/2003/XP, Linux 2.4/2.6
- -25~70°C operating temperature for hazardous environment application



- Industrial Intelligent NMS
- Rackmount PoE Plus Switch
- Industrial PoE Plus Switch
- Industrial 12-24V PoE Switch
- Industrial PoE Switch
- Rackmount L3/L2 Switch
- Gigabit Managed Switch
- Managed Ethernet Switch
- Entry-level Switch
- Wireless Outdoor AP
- Embedded PoE/Router Computer (LINUX)
- Industrial Communication Computer (WIN/LINUX)
- Ethernet/PoE/ Serial Board**
- Ethernet I/O Server
- Media Converter
- Serial Device Server
- SFP Module
- Din Rail Power Supply

### Embedded Switch Card

The JetCard 2105 is a flexible and high performance five-port Ethernet switch card in PCI-104 format. The PCI-104 bus of JetCard 2105 supports both +3.3V and +5V slot. The easy-to-install drivers that come with JetCard make it easier for you to set up your complex system. With the -25~70°C wide operating temperature range, JetCard 2105 becomes an ideal embedded networking solution for industrial applications in severe environments.

The JetCard 2105 uses Marvell 88E6065 chip to provide 5 Ethernet ports. Each Ethernet port in the JetCard offers IEEE 802.3 10 Base-T and 100 Base-Tx compliant Ethernet data transmission with auto MDI/MDI-X and auto-negotiation.

**Auto MDI/MDI-X:** The JetCard automatically determines whether or not it needs to interchange cable sense between pairs so that an external crossover cable is not required. If the JetCard interoperates with a device that cannot automatically correct for crossover, the JetCard makes the necessary adjustment prior to commencing Auto-Negotiation.

**Flow control:** The JetCard supports back-pressure and pause frame-based flow control schemes to ensure zero packet loss under temporary traffic congestion.

**QoS (Quality of Service):** QoS for networks is an industry-wide set of standards and mechanisms for ensuring high-quality performance for critical applications. JetCard provides the shared memory-based QoS switch architecture. Packets are directed into one of four traffic class queues based upon Port, IEEE 802.1p, IPv4's TOS or Diff-Serv, or IPv6's Traffic Class.

**Ethernet Statistics monitoring:** The JetCard has a set of thirty, 32-bit counters to provide a set of Ethernet statistics for frames received on ingress and transmitted on egress. A register interface allows the JetCard to capture, read, or clear the counter values.

**Customized Configurations:** The JetCard supports an add-on EEPROM for programming its internal registers.

The EEPROM data will be read in once, after JetCard is reset.

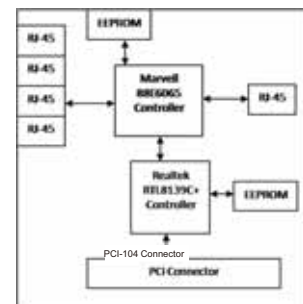

## PCI-104

The PCI-104 form factor supports the PCI bus. The maximum configuration for the PCI bus of PCI-104

modules is four plus the Host Board.

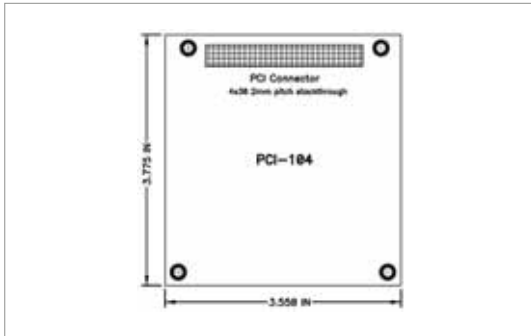
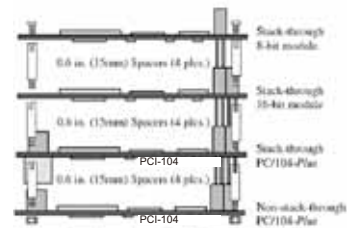
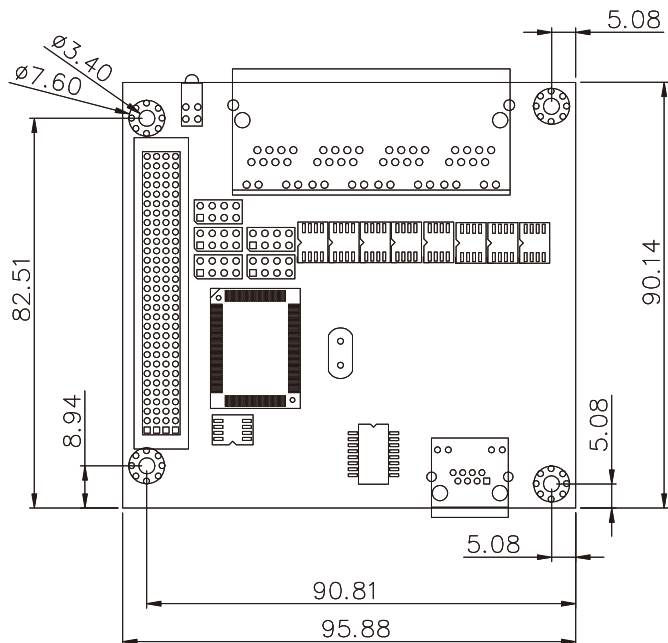

Figure 1: A Possible Module Stack Configuratuin



## Dimensions (Unit = mm)



## Specifications

### Technology

#### Standard:

IEEE802.3 10 Base-T  
 IEEE802.3u 100 Base-Tx  
 IEEE802.3x flow control and Back Pressure  
 IEEE802.1p Class of Service

**Processing:** Store and Forward architecture

### Interface

**Bus interface:** 32-bit PCI-104 bus

**Number of ports:** 4+1 Ethernet ports  
 10 Base-T/ 100 Base-Tx with auto MDI/MDI-X  
 Auto-negotiation

**Maximum stacked boards:** 4 boards plus the host board

**IRQ:** assigned by PCI-104 plug and play

### OS supported:

Windows Vista/NT/2000/2003/XP  
 Linux 2.4.x/2.6.x

### Hardware

#### Communication controller:

Realtek RTL 8139C+  
 Marvell 88E6065

**Board connector:** RJ45

#### Cable connection:

10 Base-T: 2-pair UTP/STP Cat. 3,4,5 cable (100m)  
 100 Base-Tx: 2/4-pair UTP/STP Cat. 5 cable (100m)

**Dimension:** 90 x 96 mm

### Performance

**Transfer performance:** 14,880pps for Ethernet and 148,800pps for Fast Ethernet

**Transfer packet size:** 64 to 1522bytes

**Memory buffer:** 512 Kbits

**MAC address:** 1K MAC

### Power requirement

**Power consumption:** 0.95A (+3.3V and +5V)

### Environment

#### Operating Temp:

-25 ~ 70°C (-13 ~ 158°F), 5 ~ 95% RH

**Storage Temp:** -40 ~ 80°C (-40 ~ 176°F), 5 ~ 95% RH

**Regulation:** CE, FCC

**Warranty:** 5 years

Industrial  
Intelligent  
NMS

Rackmount  
PoE Plus  
Switch

Industrial  
PoE Plus  
Switch

Industrial  
12-24V  
PoE Switch

Industrial  
PoE Switch

Rackmount  
L3/L2 Switch

Gigabit  
Managed  
Switch

Managed  
Ethernet  
Switch

Entry-level  
Switch

Wireless  
Outdoor AP

Embedded  
PoE/Router  
Computer  
(LINUX)

Industrial  
Communication  
Computer  
(WIN/LINUX)

**Ethernet/PoE/  
Serial Board**

Ethernet  
I/O Server

Media  
Converter

Serial Device  
Server

SFP Module

Din Rail  
Power Supply

## Ordering Information

### JetCard 2105 5-port 10/100Mbps Fast Ethernet Switch PCI-104 Card

Includes:

- JetCard 2105
- Quick installation guide
- Documentation and software CD-ROM
- Screw Pack

## JetCard 1608

### 4-ports RS-232/422/485 & 4-ports RS232 PCI-104 Card



CE FC  RoHS

PCI-104 4 RS 232/422/485 4 RS 232

921.6Kbps -25~70°C

- Supports 32 bit PCI-104 bus
- One DB37 connectors to support 4 RS-232/422/485 ports
- One box header to support 4 RS-232 ports
- Up to 921.6Kbps high speed data transmission
- Supports on-board automatic software flow control
- Supports Windows Vista/2000/2003/XP
- -25~70°C operating temperature for hazardous environment application



## Embedded Switch Card

The JetCard 1608 is a high performance octal asynchronous serial port card in PCI-104 format and is designed for both RS232 and high RS422/485 that is used in long distance industrial applications. JetCard 1608 PCI-104 bus support both +3.3V and +5V slot. The easy-to-install driver that come with JetCard make it easier for you to set up your complex

system. With the -25~70°C wide operating temperature range, the card becomes an ideal embedded networking solution for industrial applications in severe environments and is your best choice for applications in building automation, security, retail POS systems, billboard broadcasting, and telecom management.

## PCI-104

The PCI-104 form factor supports the PCI bus. The maximum configuration for the PCI bus of PCI-104

modules is four plus the Host Board.

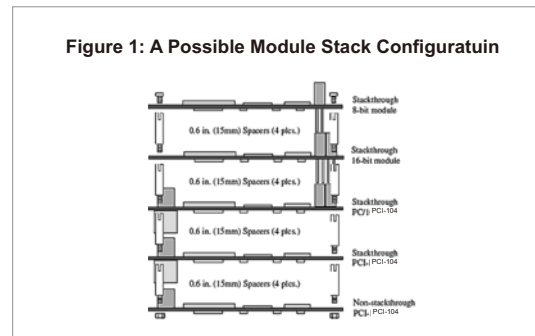
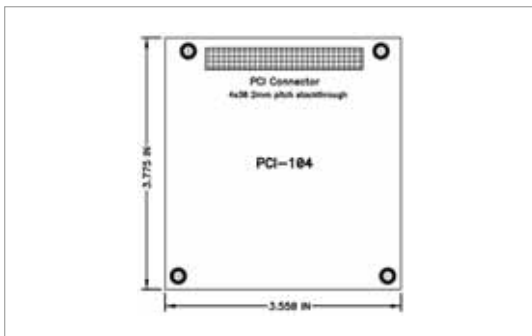

## High Performance

The JetCard 1608 uses one Oxford OXmPCI954 chip and one 16C954 chip to provide 8 serial ports. Each UART channel in the JetCard offers data transmission speed up to 921.6 Kbps, and bi-directional 128-byte FIFO for each port. Deep FIFO can reduce the CPU's loading, saving CPU's resources for other important tasks. This chip allows JetCard to be compatible with the widely-used industry-standard 16C950 devices and PCI-104 bus.

In addition to high speed of 921.6 Kbps and 128-byte FIFO, Oxford chip also equips JetCard with on-chip flow control function. Instead of using a driver on the PC to control the traffic flow, JetCard uses the on-chip flow

control function to react directly without waiting for the PC to respond. In this way, the respond time and the loading of the CPU can be largely reduced and your system performance can be greatly enhanced.

JetCard also comes with on-chip automatic flow direction switching technology. Under a multi-drop 2-wire RS-485 mode, the timing for switching between idle mode (data not being transmitted) and active mode (data being transmitted) must be precise and accurate. With this technology, JetCard can effectively increase RS-485 transmission performance, and largely relieve the PC from the burden of using the driver to switch modes.

## Dimensions (Unit = mm)

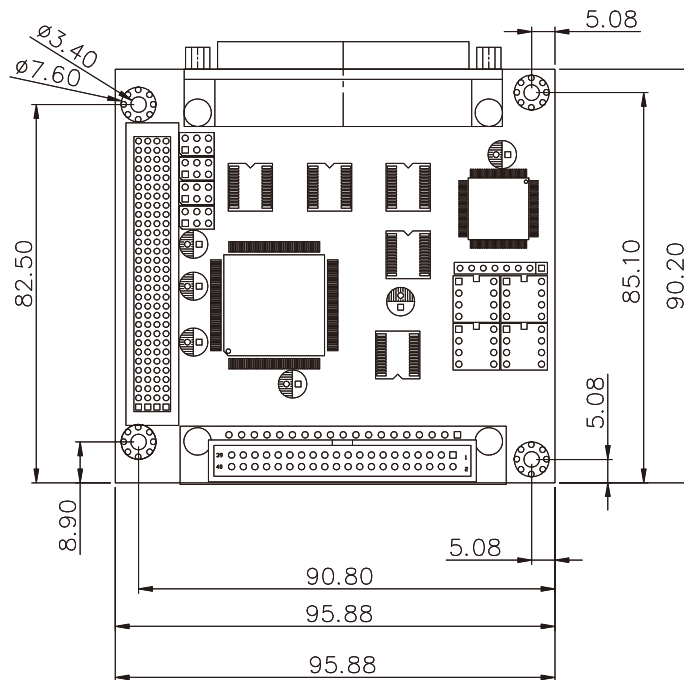

- Industrial Intelligent NMS
- Rackmount PoE Plus Switch
- Industrial PoE Plus Switch
- Industrial 12-24V PoE Switch
- Industrial PoE Switch
- Rackmount L3/L2 Switch
- Gigabit Managed Ethernet Switch
- Managed Ethernet Switch
- Entry-level Switch
- Wireless Outdoor AP
- Embedded PoE/Router Computer (LINUX)
- Industrial Communication Computer (WIN/LINUX)
- Ethernet/PoE/ Serial Board**
- Ethernet I/O Server
- Media Converter
- Serial Device Server
- SFP Module
- Din Rail Power Supply

## Specifications

### Interface

**Bus interface:** 32-bit PCI-104 plus bus

**Number of ports:**

RS232/422/485 x4 (DB37)

RS232 x4 (box header)

**Maximum boards:** 4

**IRQ:** assigned by PCI-104 plus plug and play

**Data bits:** 5, 6, 7, 8

**Stop bits:** 1, 1.5, 2

**Parity bits:** None, Even, Odd, Space, Mark

**Flow control:** Xon/Xoff, RTS/CTS, DTR/DSR

**Automatic flow direction switching** in 2-wire RS-485

**OS supported:**

Windows Vista/NT/2000/2003/XP

### Hardware

**Communication controller:**

16C950 compatible (OXFORD)

**Board connector:**

DB37 x1

Box header x1

**Cable connection:** DB9 male or DB25 male, 60cm cable length (optional accessory)

**Dimension:** 96 x 90 mm

**Net weight:** 200g

### Performance

**FIFO size:** 128 bytes

**Speed:** 50~921.6 Kbps

**Terminator:** built-in termination resistor

### Power requirement

**Power consumption:** 0.03A (+3.3V and 5V)

### Environment

**Operating Temp:**

-25 ~ 70°C (-13 ~ 158°F), 5 ~ 95% RH

**Storage Temp:** -40 ~ 80°C (-40 ~ 176°F), 5 ~ 95% RH

**Regulation:** CE, FCC

**Warranty:** 5 years

## Pin Assignments

### RS232/422/485 DB9 Male

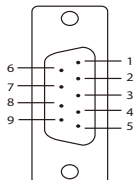

DB-9 Pin	RS-232	RS-422	RS-485 (4-wire)	RS-485 (2-wire)
1	DCD	TxD-(A)	TxD-(A)	Data-(A)
2	RxD	TxD+(B)	TxD+(B)	Data+(B)
3	TxD	RxD+(B)	RxD+(B)	
4	DTR	RxD-(A)	RxD-(A)	
5	GND	GND	GND	GND
6	DSR			
7	RTS			
8	CTS			
9				

### RS232/422/485 DB25 Male

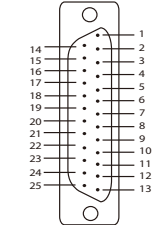

DB-25 Pin	RS-232	RS-422	RS-485 (4-wire)	RS-485 (2-wire)
2	TxD	RxD+(B)	RxD+(B)	
3	RxD	TxD+(B)	TxD+(B)	Data+(B)
4	RTS	RTS+(B)		
5	CTS	CTS+(B)		
6	DSR	RTS-(A)		
7	GND	GND	GND	GND
8	DCD		TxD-(A)	Data-(A)
20	DTR		RxD-(A)	
22				

## Ordering Information

JetCard 1608 4-ports RS-232/422/485 and 4-ports

RS-232 PCI-104 Card

Includes:

- JetCard 1608
- Quick installation guide
- Documentation and software CD-ROM
- Screw Pack

## Optional Accessories

**CM37M9x4-60**

4-port male DB37 to male DB9 connection cable, 60cm

**CM37M25x4-60**

4-port male DB37 to male DB25 connection cable, 60cm



CM37M9x4-60



CM37M25x4-60

## JetCard 2215

### 4 PoE, 1 LAN, 12~24V Booster Switch Universal PCI Card



CE FC  RoHS

UPCI 4 PoE 12~24V Booster  
60W -25~70°C

- Supports 32 bit Universal PCI bus
- 5 10/100TX ports with Auto MDI/MDI-X
- One 12~24V DC input powers PCI card and PoE ports
- 4 ports PoE, IEEE 802.3af compliant, deliver 15.4W per port, 60W per unit
- Unmanaged switch function
- IEEE 802.3 10 Base-T and 100 Base-Tx compatible
- Full or half duplex at 10/100 Mbps
- IEEE 802.3u Auto-Negotiation supported
- Supports Windows Vista/NT/2000/2003/XP
- -25~70°C operating temperature for hazardous environment application



- Industrial Intelligent NMS
- Rackmount PoE Plus Switch
- Industrial PoE Plus Switch
- Industrial 12-24V PoE Switch
- Industrial PoE Switch
- Rackmount L3/L2 Switch
- Gigabit Managed Switch
- Managed Ethernet Switch
- Entry-level Switch
- Wireless Outdoor AP
- Embedded PoE/Router Computer (LINUX)
- Industrial Communication Computer (WIN/LINUX)
- Ethernet/PoE/ Serial Board**
- Ethernet I/O Server
- Media Converter
- Serial Device Server
- SFP Module
- Din Rail Power Supply

## Embedded Switch Card

The JetCard 2215 is a flexible and high performance five-port Ethernet PoE switch card in Universal PCI format. The easy-to-install drivers that come with JetCard make it easier for you to set up your complex system. JetCard 2215 is ideal embedded networking solution for industrial applications.

### 12~24V DC Power Booster for 48V PoE

The JetCard 2215 has an on board power module to adopt 12~24V DC input and then using +3.3V and +5V for PCI card system boost to 48V for for 802.3af standard PoE devices.

### IEEE 802.3af Power over Ethernet

The JetCard is IEEE802.3af standard compliant and works as a PSE (power sourcing device) to deliver 15.4W per port.

### Unmanaged Ethernet Switch Function

The JetCard 2215 uses Marvell 88E6065 chip to provide 5 Ethernet ports. Each Ethernet port in the JetCard offers IEEE 802.3 10 Base-T and 100 Base-Tx compliant Ethernet data transmission with auto MDI/MDI-X and auto-negotiation.

### Auto MDI/MDI-X

The JetCard automatically determines whether or not it needs to interchange cable sense between pairs so that an external crossover cable is not required. If the JetCard interoperates with a device that cannot automatically correct for crossover, the JetCard makes the necessary adjustment prior to commencing Auto-Negotiation.

**Flow control:** The JetCard supports back- pressure and pause frame-based flow control schemes to ensure zero packet loss under temporary traffic congestion.

## Dimensions (Unit = mm)

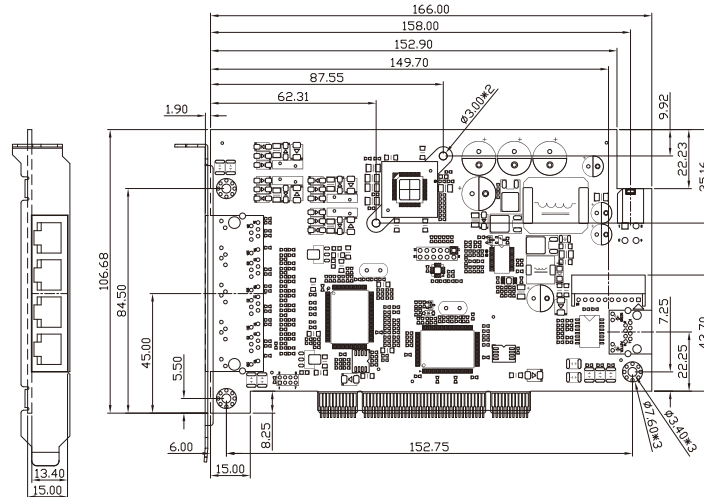

## Specifications

### Technology

#### Standard:

IEEE802.3 10 Base-T  
IEEE802.3u 100 Base-Tx  
IEEE802.3x flow control and Back Pressure  
IEEE802.3af PoE

**Processing:** Store and Forward architecture

### Interface

**Bus interface:** 32-bit Universal PCI bus

**Number of ports:** 10/100 Base-Tx RJ45 x5 (4 ports use RJ45 connectors and support PoE function; 1 port use both RJ45 & JST connectors and is reserved for internal connection)  
10 Base-T/ 100 Base-Tx with auto MDI/MDI-X Auto-negotiation

**IRQ:** assigned by Universal PCI plug and play

### OS supported:

Windows Vista/NT/2000/2003/XP  
Linux 2.4.x/2.6.x

### PoE Technology

**PD classification:** detection, class ID 0~3 follow

IEEE802.3af standard

**PIN assignment (RJ45 connector):** V+ (Pin 4,5), V- (Pin 7,8), Tx (Pin 1,2), Rx (Pin 3,6)

**Power Limit Control:** The control mode supports IEEE802.3af standard. The maximum DC power delivery on each PoE is 15.4W@DC 48V input.

### Hardware

#### Communication controller:

Realtek RTL 8139C+  
Marvell 88E6065

**Board connector:** RJ45

#### Cables:

10Base-T: 4-pair UTP/STP Cat 3,4,5, 100ohm (100m) for PoE  
100Base-Tx: 4-pair UTP/STP Cat.5, 100ohm (100m) for PoE

**Dimension:** 107 x 166 mm

**Net weight:** 300g

### Performance

**Transfer performance:** 14,880pps for Ethernet  
and 148,800pps for Fast Ethernet

**Transfer packet size:** 64 to 1522bytes

**MAC address:** 1K MAC

**Memory buffer:** 512 Kbits

### Power requirement

**Power input:** DC 12~24V (ATX 4P connector) for system use  
and PoE function

**Power consumption:** 80W including PoE

### Environment

#### Operating Temp:

-25 ~ 70°C (-13 ~ 158°F), 5 to 95% RH

**Storage Temp:** -40 ~ 80°C (-40 ~ 176°F), 5 ~ 95% RH

**Regulation:** CE, FCC Class A (Surge:0.5KV; ESD contact 4KV; Air 8KV)

**Warranty:** 5 years

## Ordering Information

### JetCard 2215 4 PoE, 1 LAN, 12~24V Booster, Switch UPCI Card

Includes:

- JetCard 2215
- DC Connector Cable, ATX R4 pin to L4 pin, 30cm
- Quick installation guide
- Documentation and software CD-ROM

## JetCard 2205

### 5-ports 10/100Mbps Fast Ethernet Switch Universal PCI Card



CE FC RoHS

UPCI

QoS

-25~70°C

- Supports 32 bit Universal PCI bus
- 5 10/100TX ports with Auto MDI/MDI-X
- IEEE 802.3 10 Base-T and 100 Base-Tx compatible
- Full or half duplex at 10/100 Mbps
- IEEE 802.3u Auto-Negotiation supported
- QoS supported for packet forwarding precedence
- Supports Windows Vista/NT/2000/2003/XP, Linux 2.4/2.6
- -25~70°C operating temperature for hazardous environment application



- Industrial Intelligent NMS
- Rackmount PoE Plus Switch
- Industrial PoE Plus Switch
- Industrial 12-24V PoE Switch
- Industrial PoE Switch
- Rackmount L3/L2 Switch
- Gigabit Managed Ethernet Switch
- Managed Ethernet Switch
- Entry-level Switch
- Wireless Outdoor AP
- Embedded PoE/Router Computer (LINUX)
- Industrial Communication Computer (WIN/LINUX)
- Ethernet/PoE/ Serial Board**
- Ethernet I/O Server
- Media Converter
- Serial Device Server
- SFP Module
- Din Rail Power Supply

## Embedded Switch Card

The JetCard 2205 is a flexible and high performance five-port Ethernet switch card in Universal PCI format. The universal PCI bus of JetCard 2205 supports both +3.3V and +5V slots. The easy-to-install drivers that come with JetCard make it easier for you to set up your complex system. With the -25~70°C wide operating temperature range, JetCard 2205 is an ideal embedded networking solution for industrial applications in severe environments.

The JetCard 2205 uses Marvell 88E6065 chip to provide 5 Ethernet ports. Each Ethernet port in the JetCard offers IEEE 802.3 10 Base-T and 100 Base-Tx compliant Ethernet data transmission with auto MDI/MDI-X and auto-negotiation.

**Auto MDI/MDI-X:** The JetCard automatically determines whether or not it needs to interchange cable sense between pairs so that an external crossover cable is not required. If the JetCard interoperates with a device that cannot automatically correct for crossover, the JetCard makes the necessary adjustment prior to commencing Auto-Negotiation.

**Flow control:** The JetCard supports back-pressure and pause frame-based flow control schemes to ensure zero packet loss under temporary traffic congestion.

**QoS (Quality of Service):** QoS for networks is an industry-wide set of standards and mechanisms for ensuring high-quality performance for critical applications. JetCard provides the shared memory-based QoS switch architecture. Packets are directed into one of four traffic class queues based upon Port, IEEE 802.1p, IPv4's TOS or Diff-Serv, or IPv6's Traffic Class.

**Ethernet Statistics monitoring:** The JetCard has a set of thirty, 32-bit counters to provide a set of Ethernet statistics for frames received on ingress and transmitted on egress. A register interface allows the JetCard to capture, read, or clear the counter values.

**Customized Configurations:** The JetCard supports an add-on EEPROM for programming its internal registers.

The EEPROM data will be read in once, after JetCard is reset.

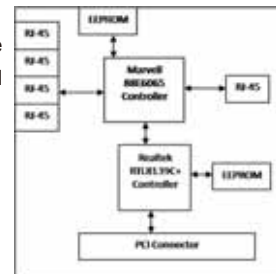

## Dimensions (Unit = mm)

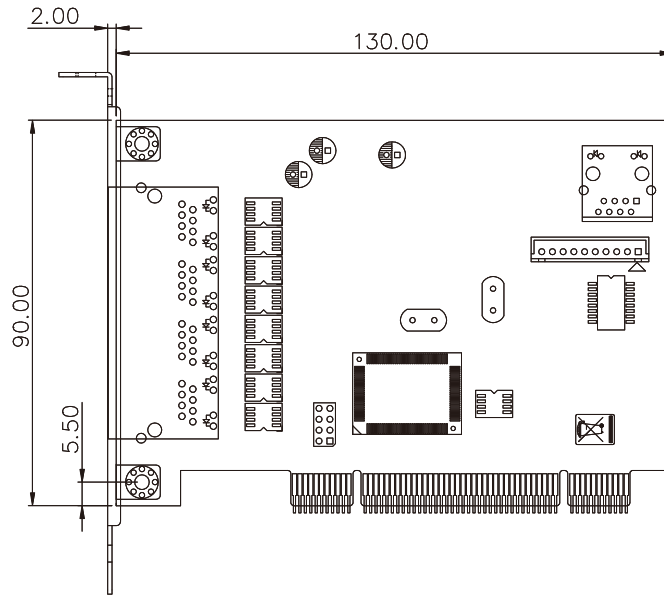

## Specifications

### Technology

#### Standard:

IEEE802.3 10 Base-T  
 IEEE802.3u 100 Base-Tx  
 IEEE802.3x flow control and Back Pressure  
 IEEE802.1p Class of Service

**Processing:** Store and Forward architecture

#### Interface

**Bus interface:** 10/100 Base-Tx RJ45 x5

**Number of ports:** 4+1 Ethernet ports  
 10 Base-T/ 100 Base-Tx with auto MDI/MDI-X  
 Auto-negotiation

IRQ: assigned by Universal PCI plug and play

#### OS supported:

Windows Vista/NT/2000/2003/XP  
 Linux 2.4.x/2.6.x

#### Hardware

**Communication controller:**

Realtek RTL 8139C+  
 Marvell 88E6065

**Board connector:** RJ45

#### Cable connection:

10 Base-T: 2-pair UTP/STP Cat. 3,4,5 cable (100m)  
 100 Base-Tx: 2-pair UTP/STP Cat. 5 cable (100m)

**Dimension:** 90 x 130 mm

#### Performance

**Transfer performance:** 14,880bps for Ethernet and 148,800bps for Fast Ethernet

**Transfer packet size:** 64 to 1522bytes

**Memory buffer:** 512Kbits

**MAC address:** 1K MAC

#### Power requirement

**Power consumption:** 0.95A (+3.3V and +5V)

#### Environment

**Operating Temp:** -25 ~ 70°C (-13 ~ 158°F), 5 ~ 95% RH

**Storage Temp:** -40 ~ 80°C (-40 ~ 176°F), 5 ~ 95% RH

**Regulation:** CE, FCC

**Warranty:** 5 years

## Ordering Information

### JetCard 2205 5-port 10/100Mbps Fast Ethernet Switch Universal PCI Card

Includes:

- JetCard 2205
- Quick installation guide
- Documentation and software CD-ROM

## JetCard 1208L

### 8-port RS-232 Universal PCI Low Profile Card



CE FC  RoHS

Low Profile 8 RS 232 UPCI

15KV ESD 921.6Kbps Win 7

- Supports 32-bit Universal PCI bus
- Low profile form factor fits small-sized PCs
- Easy-to-install driver and self-diagnostic utility
- High speed up to 921.6 Kbps
- Built-in 15KV ESD protection
- Supports 128-byte FIFO
- Supports on-board automatic hardware/ software flow control
- Supports Windows 7/Vista/Me/2000/XP, Linux 2.4/2.6
- -10~70°C operating temperature for hazardous environment application



- Industrial Intelligent NMS
- Rackmount PoE Plus Switch
- Industrial PoE Plus Switch
- Industrial 12-24V PoE Switch
- Industrial PoE Switch
- Rackmount L3/L2 Switch
- Gigabit Managed Switch
- Managed Ethernet Switch
- Entry-level Switch
- Wireless Outdoor AP
- Embedded PoE/Router Computer (LINUX)
- Industrial Communication Computer (WIN/LINUX)
- Ethernet/PoE/ Serial Board**
- Ethernet I/O Server
- Media Converter
- Serial Device Server
- SFP Module
- Din Rail Power Supply

### Overview

JetCard 1208L is Korenix's 8-port RS-232 Universal PCI Low Profile Communication Card, which supports both 3.3V and 5V slots and is specifically designed to fit in small systems. The 8-port UPCI low profile card

allows users to connect multiple serial devices to the host becoming an ideal solution for applications in retail and POS systems, traffic operation centers, banking systems, etc.

### High Performance

JetCard Series use Oxford OXmPCI954 chip, an 8-port Universal Asynchronous Receiver Transmitter, which is well-known for its high performance. Each UART channel in the JetCard offers data transmission speed up to 921.6 Kbps, and bi-directional 128-byte FIFO for each port. Deep FIFO can reduce the CPU's loading, saving CPU's resources for other important tasks. This chip also allows JetCard to be compatible with the widely-used industry-standard 16C950 devices and PCI bus. In addition to high speed of 921.6 Kbps and 128-byte FIFO, Oxford chip also equips JetCard with on-board flow control function. Instead of using a driver on the PC to control the traffic flow, JetCard uses the onboard flow control function to react directly

without waiting for the PC to respond. In this way, the respond time and CPU's loading can be largely reduced, greatly enhancing your system's performance. You can either choose software flow control, which uses Tx and Rx to send/ receive XON/ XOFF signals, or select hardware flow control, which uses CTS#/RTS# to send/ receive the signals. The flow control function is to prevent FIFO from overflow. JetCard is ideally suitable for PC applications, enabling PC users to take advantage of the maximum performance of analog modem or ISDN terminal adapters. JetCard is also suitable for any communications that require high speed RS-232/RS-422/RS-485 interfaces.

## Dimensions (Unit = mm)

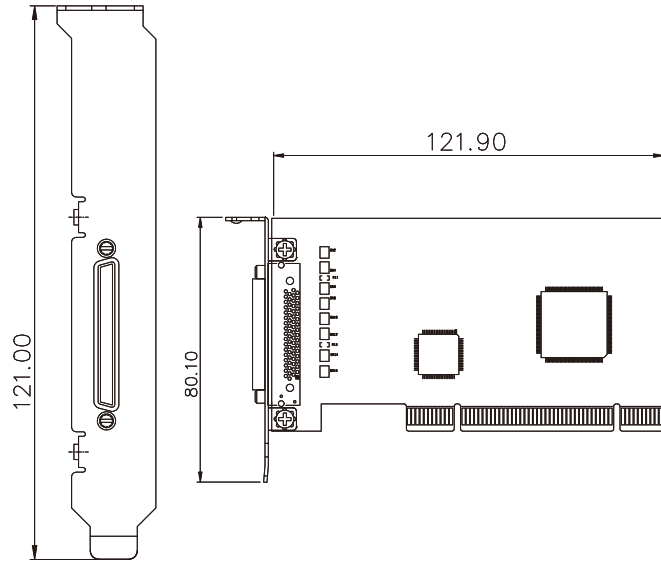

Standard Bracket

## Pin Assignments

### Board Side Pin Assignments-Female SCSI VHDCI68



Pin	Signal	Pin	Signal	Pin	Signal	Pin	Signal	Pin	Signal	Pin	Signal
1	RxD6	13	DCD4	25	TxD2	37	RI7	49	RI5	61	TxD1
2	CTS6	14	RTS4	26	GND	38	RTS7	50	CTS5	62	DSR1
3	RI6	15	RI4	27	TxD0	39	DCD7	51	RxD5	63	DTR1
4	RTS6	16	CTS4	28	DSR0	40	DTR7	52	RxD3	64	DCD1
5	DCD6	17	RxD4	29	DTR0	41	DSR7	53	CTS3	65	RTS1
6	DTR6	18	RxD2	30	DCD0	42	TxD7	54	RI3	66	RI1
7	DSR6	19	CTS2	31	RTS0	43	GND	55	TRS3	67	CTS1
8	TxD6	20	RI2	32	RI0	44	TxD5	56	DCD3	68	RxD1
9	GND	21	RTS2	33	CTS0	45	DSR5	57	DTR3		
10	TxD4	22	DCD2	34	RxD0	46	DTR5	58	DSR3		
11	DSR4	23	DTR2	35	RxD7	47	DCD5	59	TxD3		
12	DTR4	24	DSR2	36	CTS7	48	RTS5	60	GND		

## Specifications

### Interface

**Bus interface:** 32-bit Universal PCI Low Profile

**Number of ports:** 8

**Max. Number of Boards:** 4

IRQ: Assigned by PCI plug and play

Data Bits: 5, 6, 7, 8

Stop Bits: 1, 1.5, 2

Parity Bits: None, Even, Odd, Space, Mark

Data Signals: TxD, RxD, RTS, CTS, DTR, DSR, DCD, GND

### Hardware

**Communication controller:** 16C954 compatible (OXFORD)

**Board connector:** VHDCI 68

**Cable connection:** DB9 Male or DB25 Male, 100 cm (optional)

### Performance

**FIFP Size:** 128 bytes

**Seppd:** 50 bps to 921.6 Kbps

**Surge protection:** built-in 15KV ESD surge protection

### Power Requirements

**Power Consumption:** 130 mA (+5 V)

### Mechanical

**Dimensions:** 120 x 64.4 mm

### Environmental

**Operating Temperature:** -10 ~ 70°C (14 ~ 158°F)

**Storage Temperature:** -20 ~ 85°C (-4 ~ 185°F)

### OS Supported:

Windows 7 / Vista / Me / 2000 / XP

Linux RedHat Enterprise 4.0 (2.6.9)/RedHat Enterprise 3.0 (2.4.21)/RedHat 9.0 (2.4.20)/RedHat 8.0 (2.4.18)/

RedHat 7.3 (2.4.18)/RedHat 7.2 (2.4.7)/FC5(2.6.16)/FC3(2.6.9)/FC2(2.6.5)/FC1(2.4.22)/Mandrake 10.1(2.6.8)/Mandrake 9.2 (2.4.22)

### Regulatory Approvals

**EMI:** FCC, CE

**Warranty:** 5 years

Industrial  
Intelligent  
NMS

Rackmount  
PoE Plus  
Switch

Industrial  
PoE Plus  
Switch

Industrial  
12-24V  
PoE Switch

Industrial  
PoE Switch

Rackmount  
L3/L2 Switch

Gigabit  
Managed  
Switch

Managed  
Ethernet  
Switch

Entry-level  
Switch

Wireless  
Outdoor AP

Embedded  
PoE/Router  
Computer  
(LINUX)

Industrial  
Communication  
Computer  
(WIN/LINUX)

**Ethernet/PoE/  
Serial Board**

Ethernet  
I/O Server

Media  
Converter

Serial Device  
Server

SFP Module

Din Rail  
Power Supply

## Ordering Information

### JetCard 1208L 8-ports RS-232 Universal PCI Low Profile Card

Includes:

- JetCard 1208L
- Standard bracket and low profile bracket
- Quick installation guide
- Documentation and software CD-ROM

## Optional Accessories

### CV68M9x8-100

Male VHDCI 68 to 8-port male DB9 connection cable, 100cm

### CV68M25x8-100

Male VHDCI 68 to 8-port male DB25 connection cable, 100cm



CV68M9x8-100



CV68M25x8-100